

1. test dimension
2. wall
3. door/window
4. masonry
5. masonry
6. masonry
7. border
8. border
9. paper edges
10. scratch

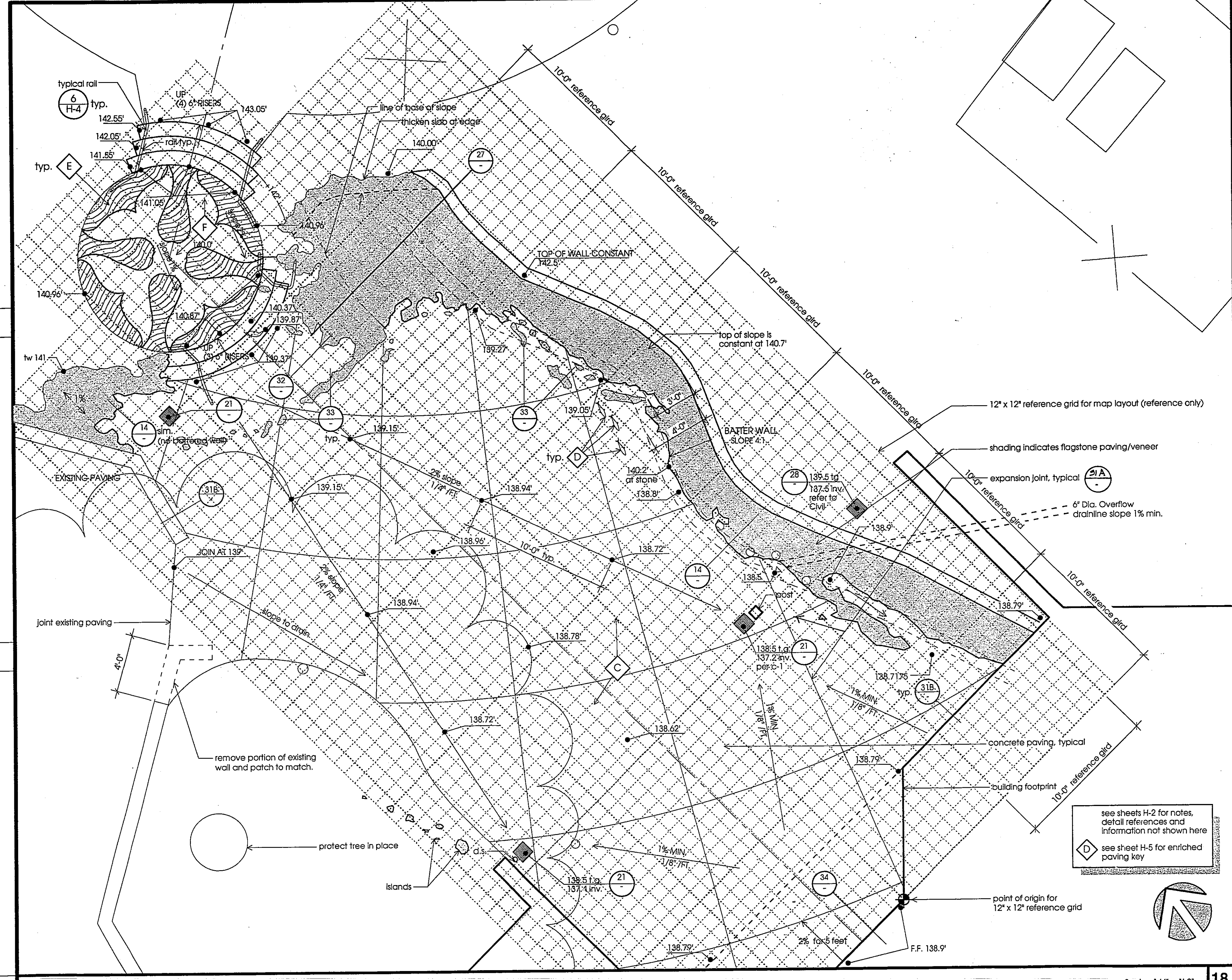

STONE PAVING MAP LAYOUT PLAN

Scale: 1/4" = 1'-0"

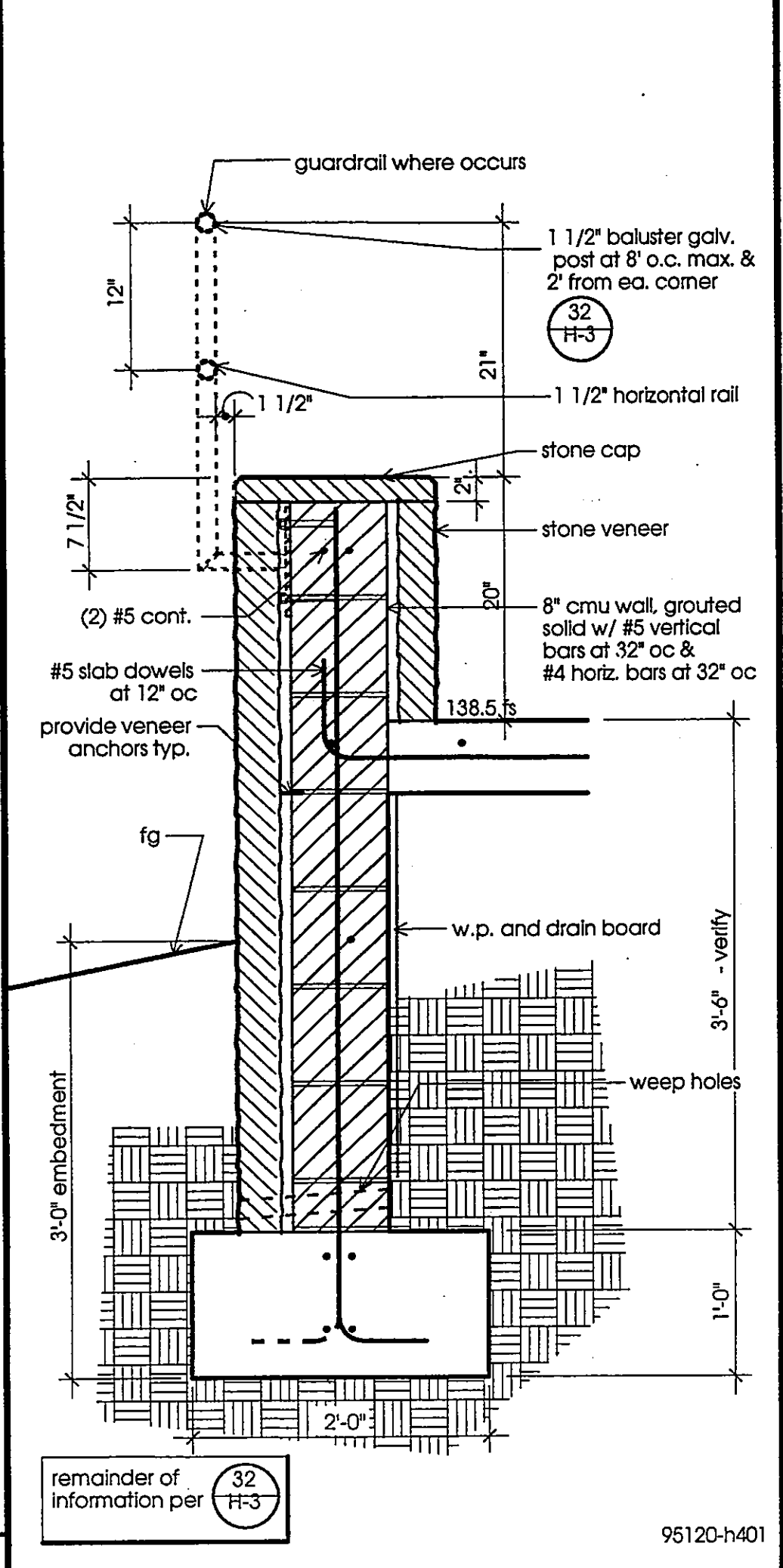

TERRACE WALL

Scale: 1" = 1'-0"

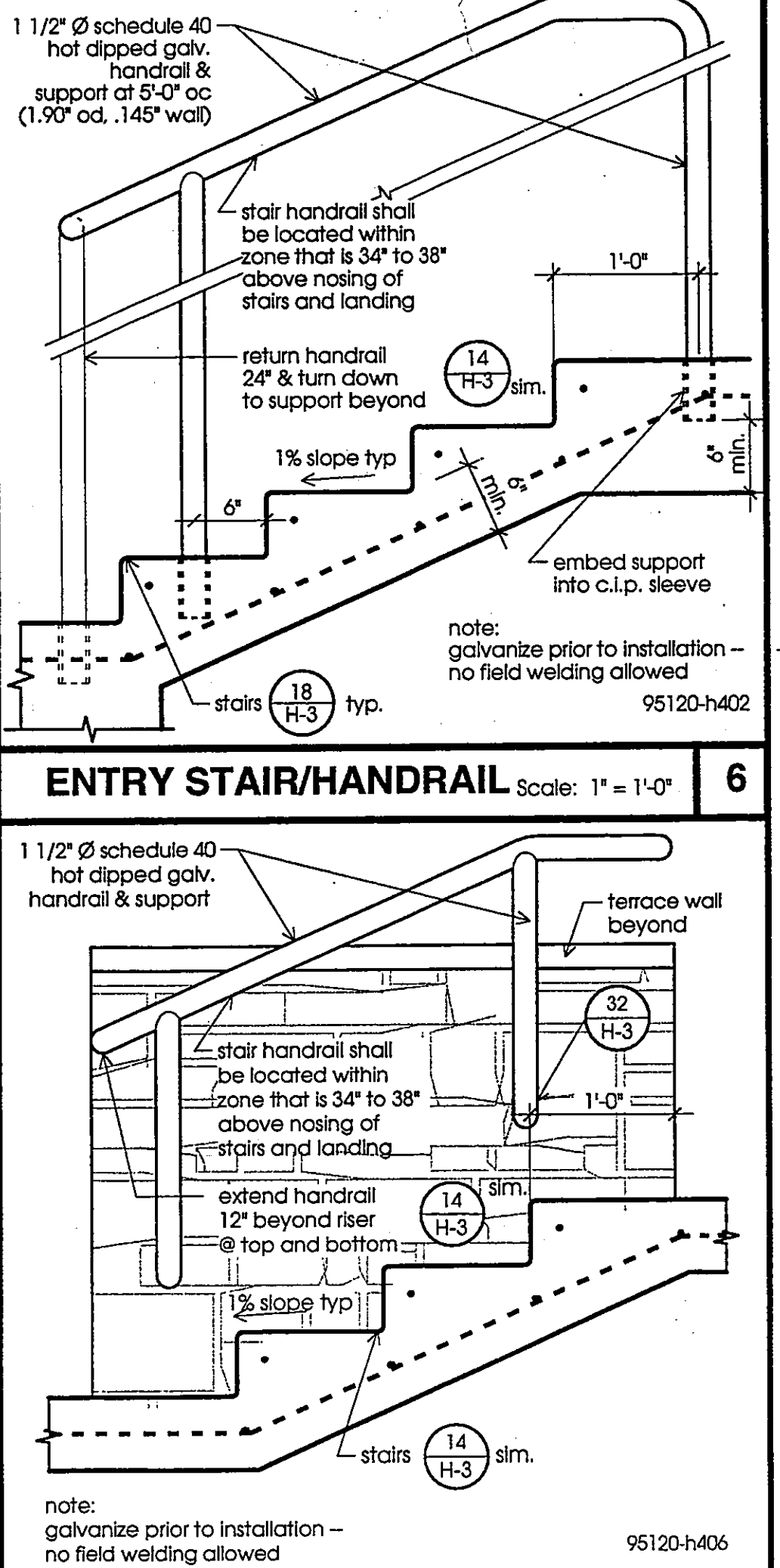

ENTRY STAIR/HANDRAIL

Scale: 1" = 1'-0"

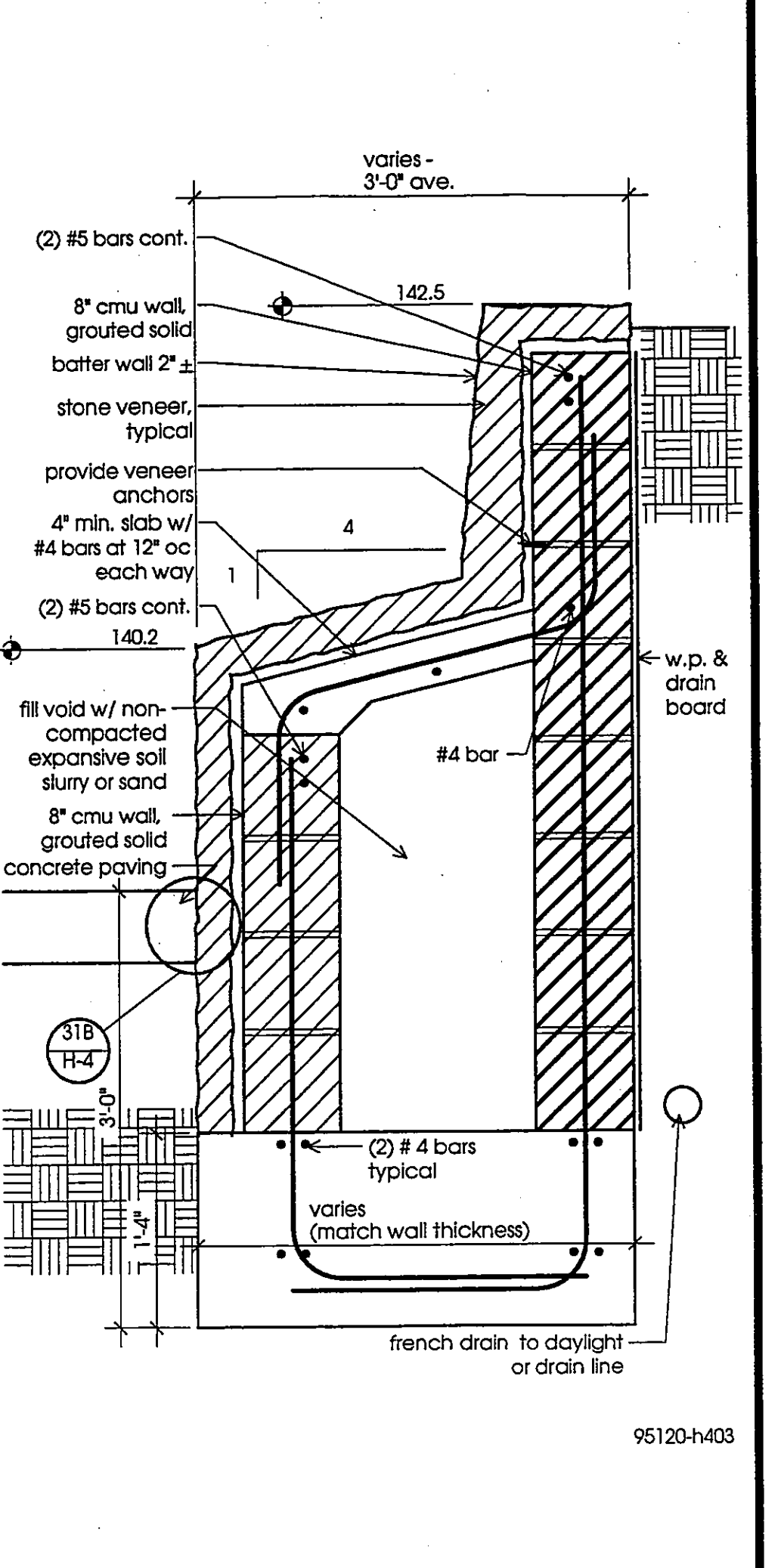

MIGRATION MAP SEATWALL

Scale: 1" = 1'-0"

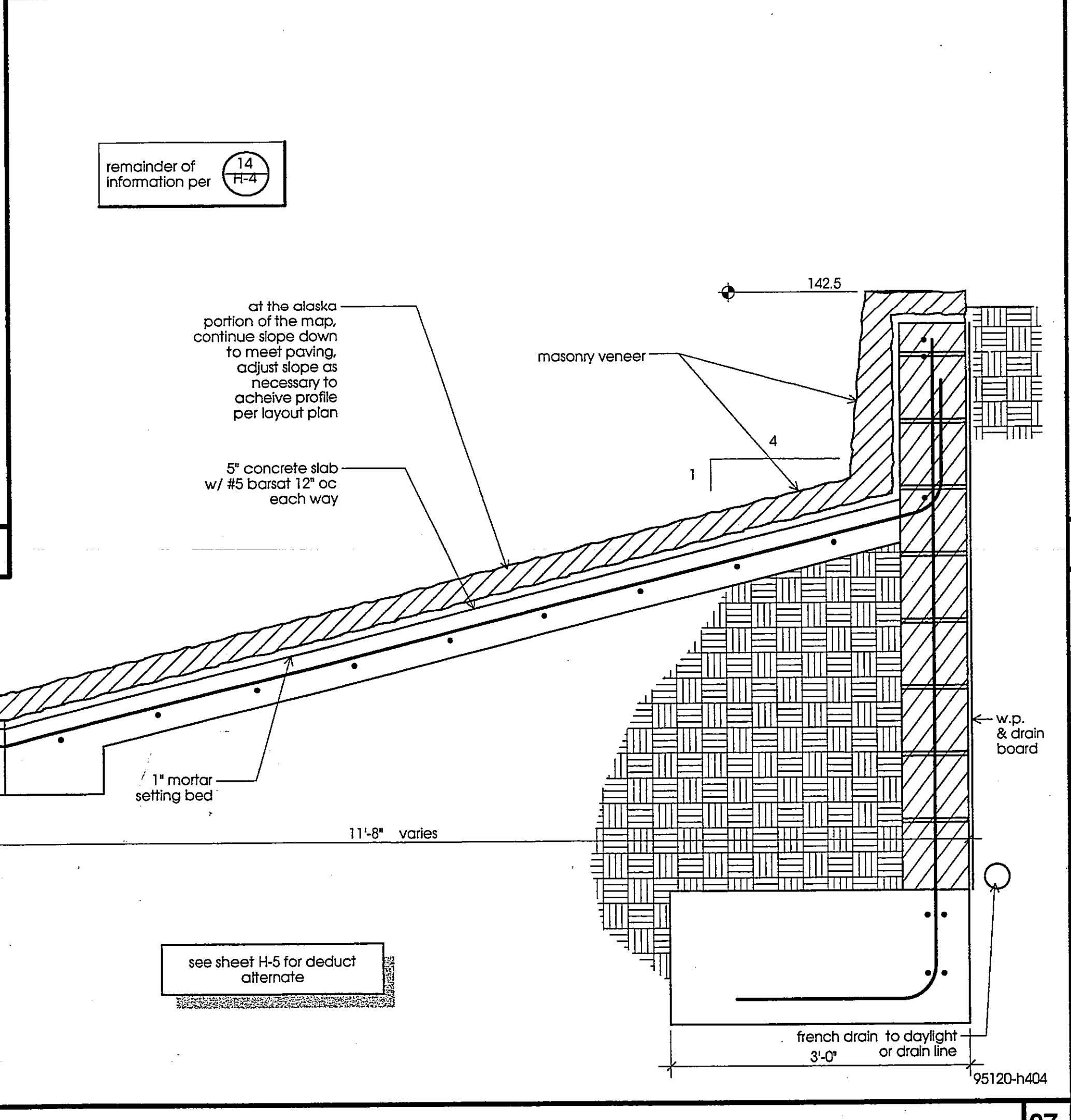

TERRACE STAIR

Scale: 1" = 1'-0"

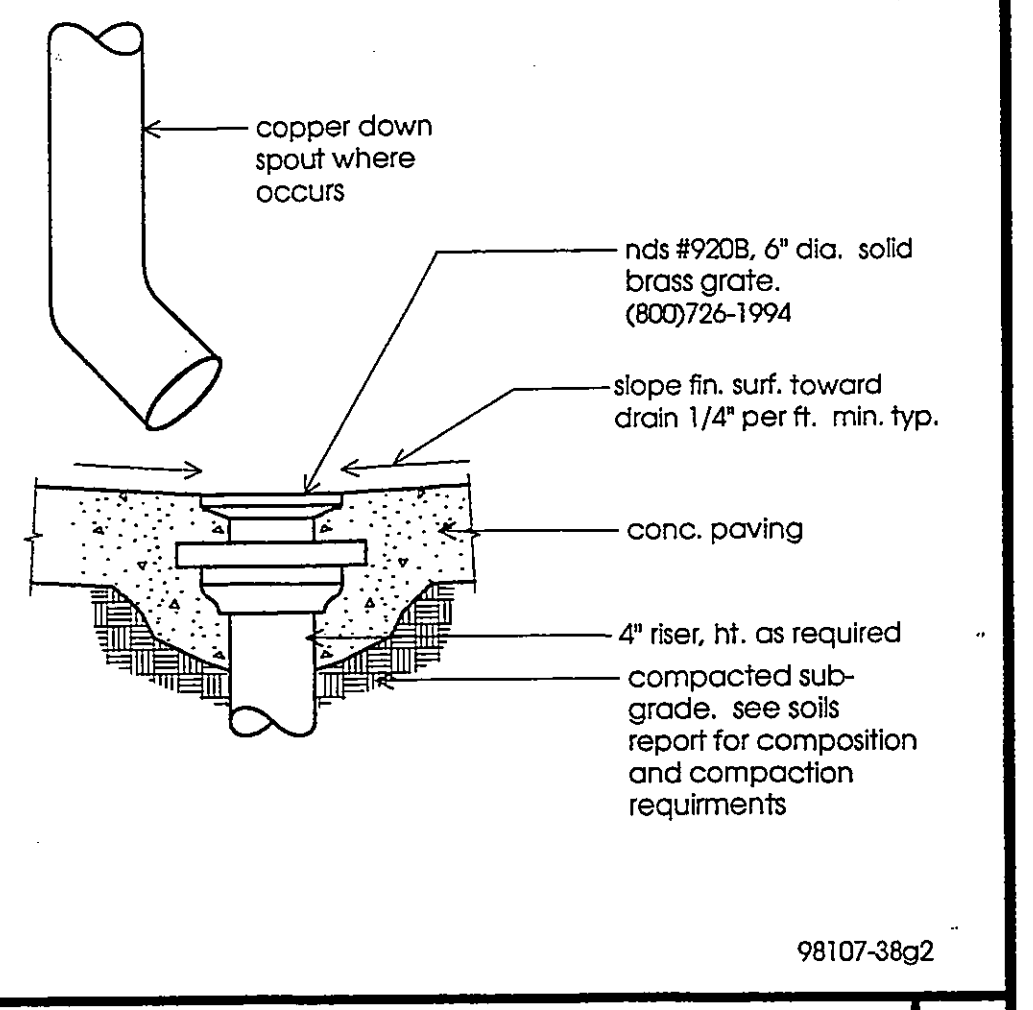

PAVING AREA DRAIN

Scale: 1 1/2" = 1'-0"

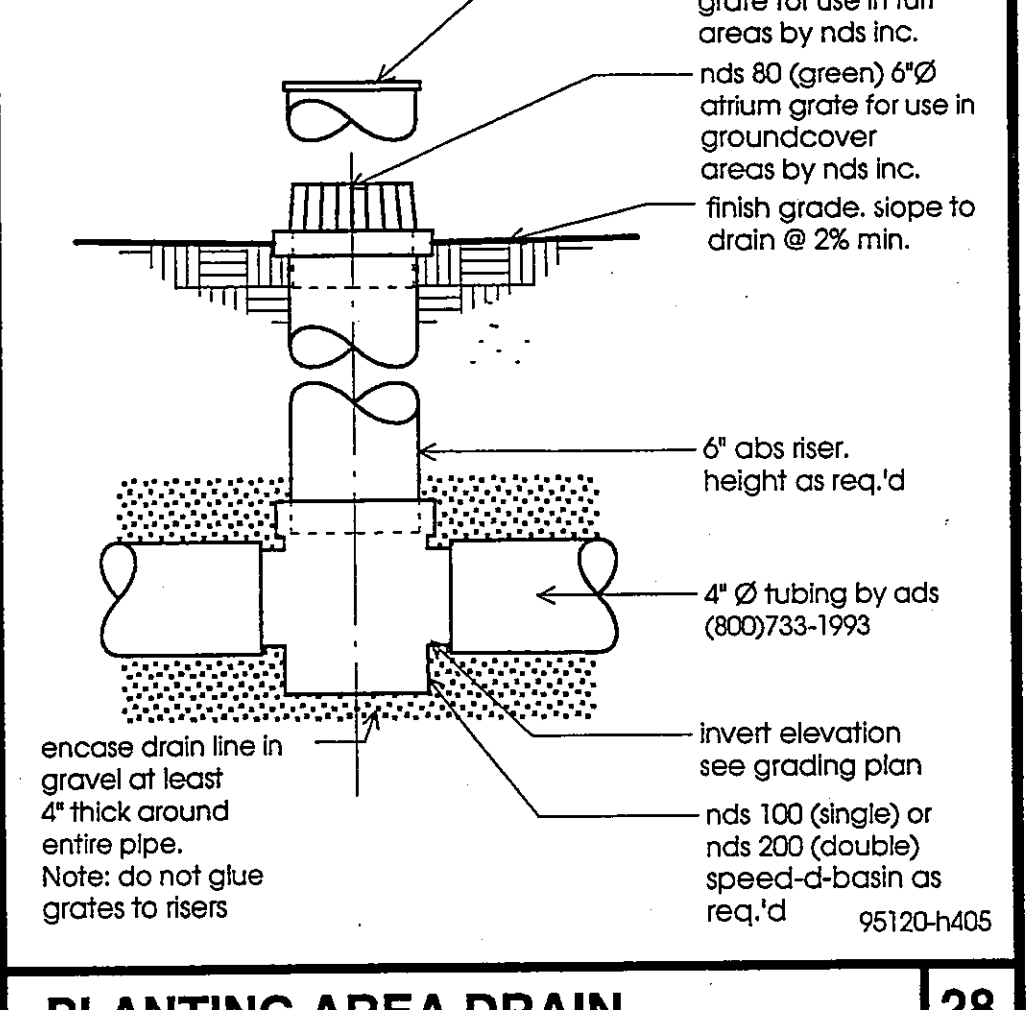

PLANTING AREA DRAIN

Scale: none

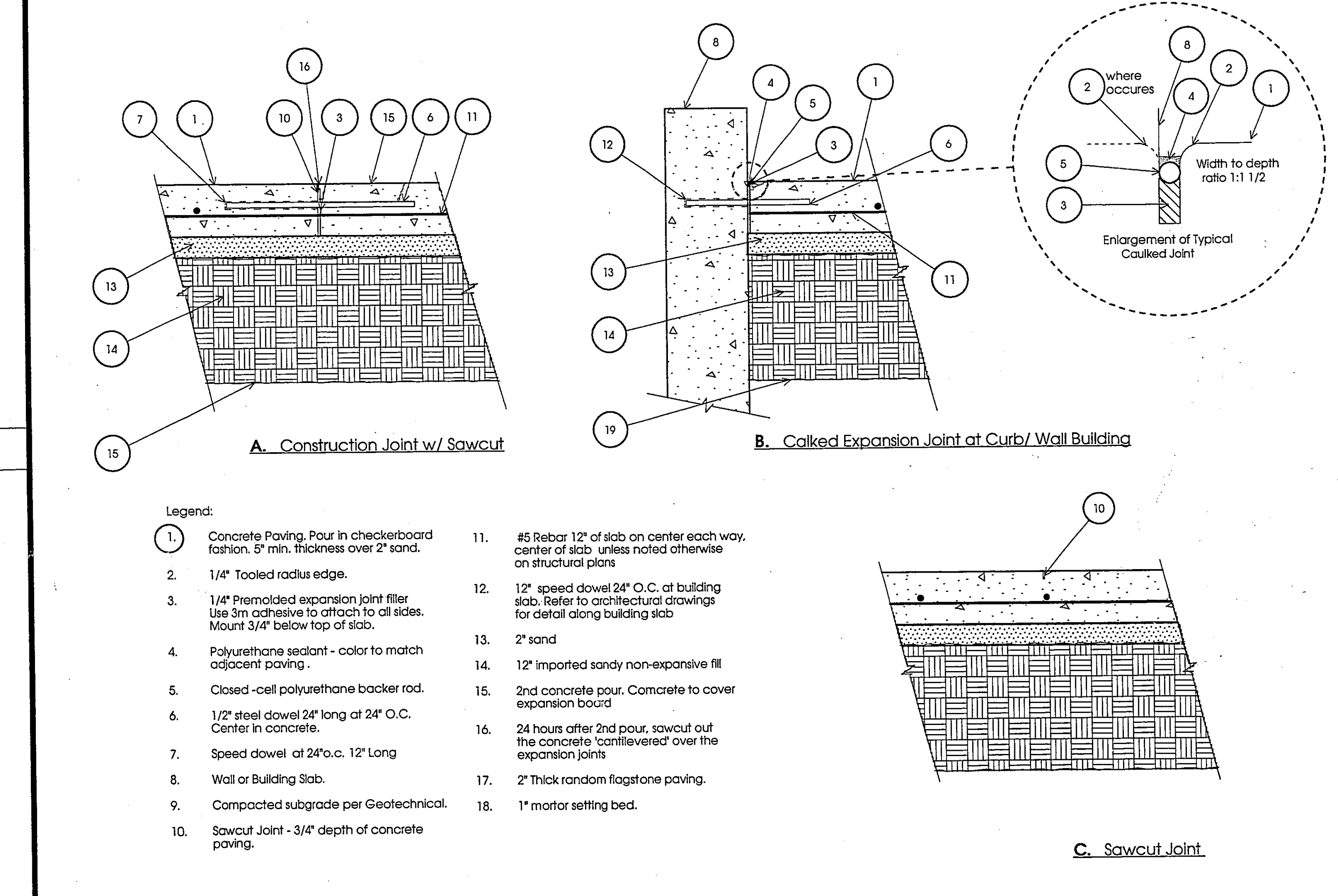

PAVING JOINTS

Scale: none

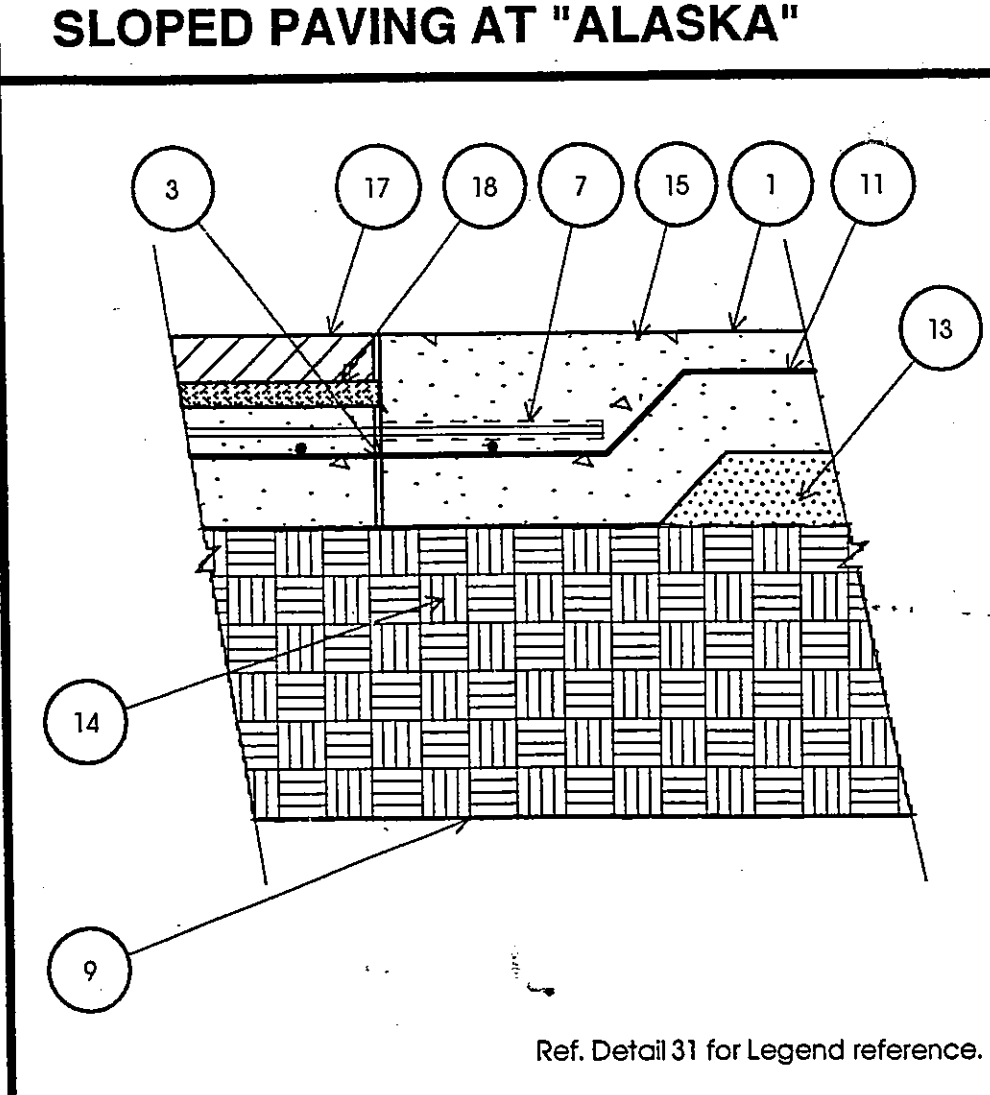

SLOPED PAVING AT "ALASKA"

Scale: 1" = 1'-0"

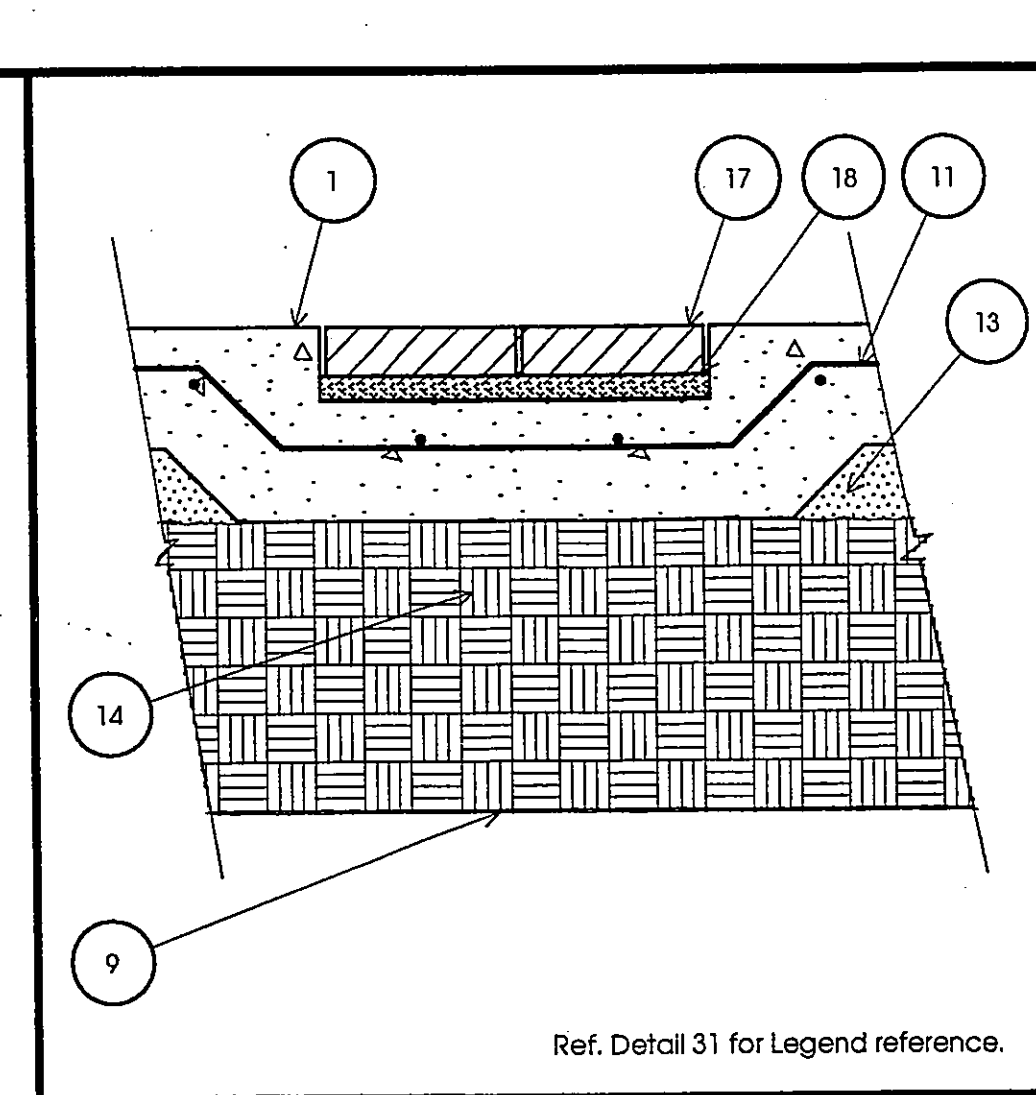

ISLAND

Scale: none

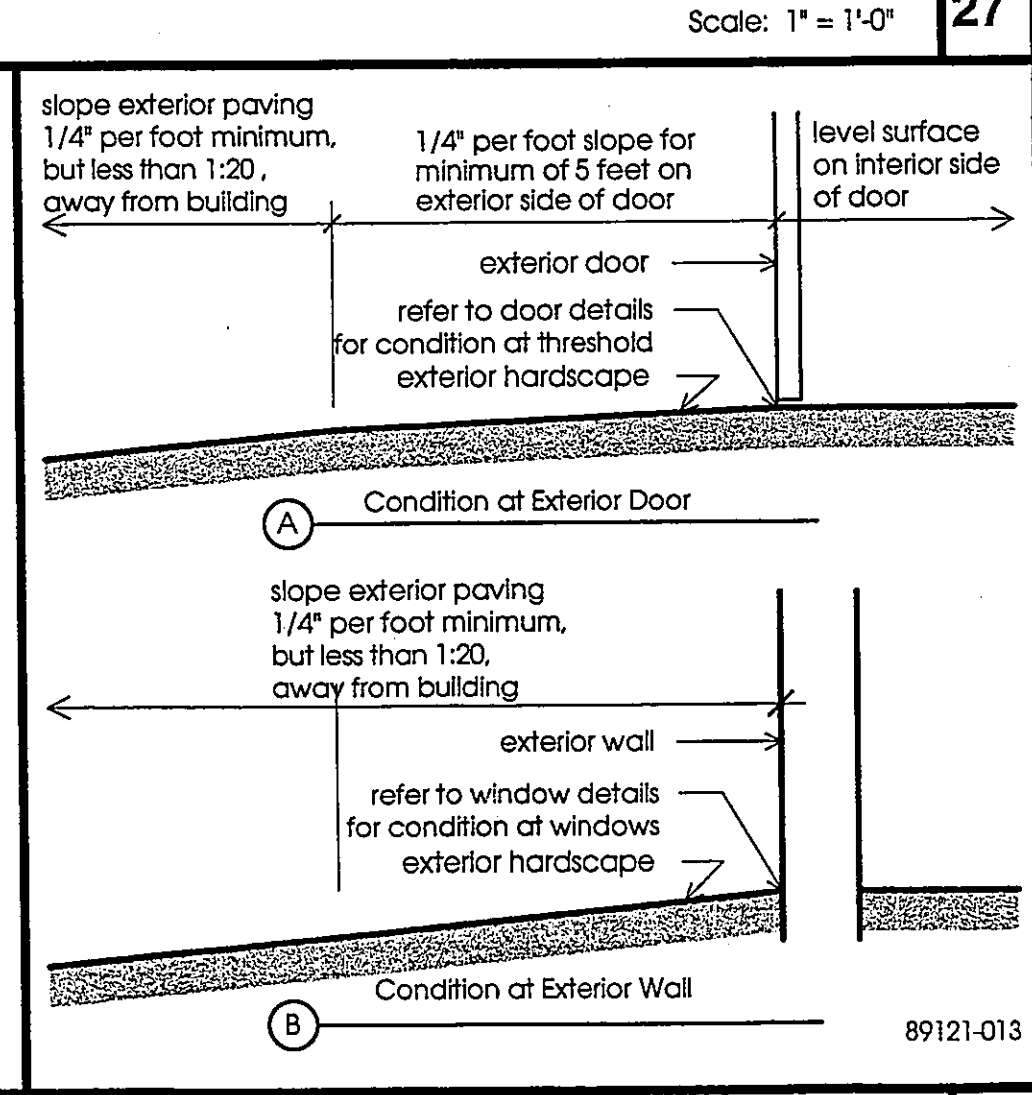

HARDSCAPE @ BLDG.

Scale: none

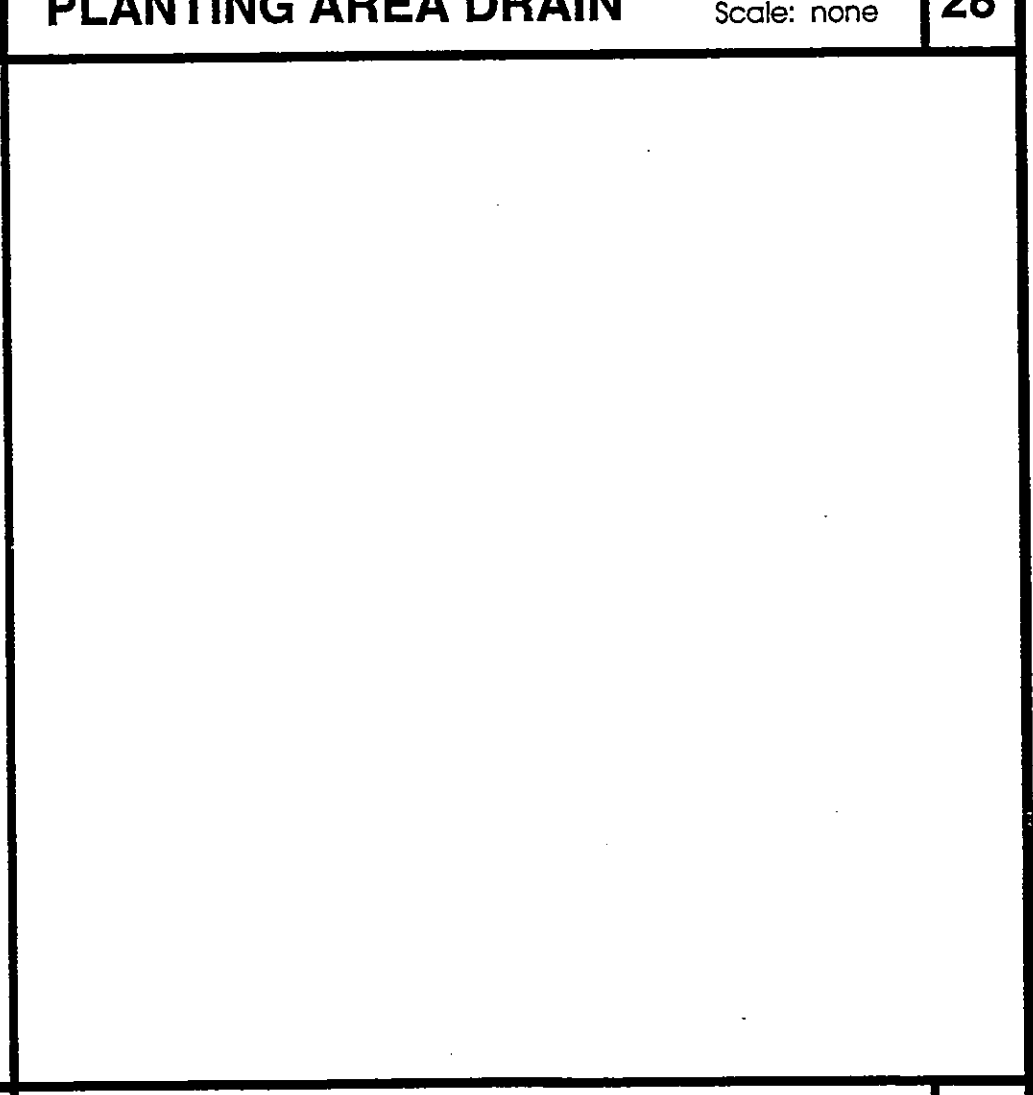

DETAIL TITLE

Scale: 1/1/2" = 1'-0"

RON YEO, FAIA ARCHITECT, INC.
 500 JASMINE AVENUE, CORONA DEL MAR, CA 92625
 CALIFORNIA LICENSED PROFESSIONAL ARCHITECT
 PATRICK MARRE, AIA, PE, ASSOCIATE ARCHITECT



POINT VICENTE INTERPRETIVE CENTER EXPANSION
 3115011 Palms Verde Drive West
 Rancho Palms Verde, CA

Hardscape Details & Sections

H-4
 5 OF 9 SHEETS

DMC EXPANSION BUILDING PLANS
 12/23/03 update revisions
 Construction Set