

WOOD SPLIT-RAIL FENCE DETAIL

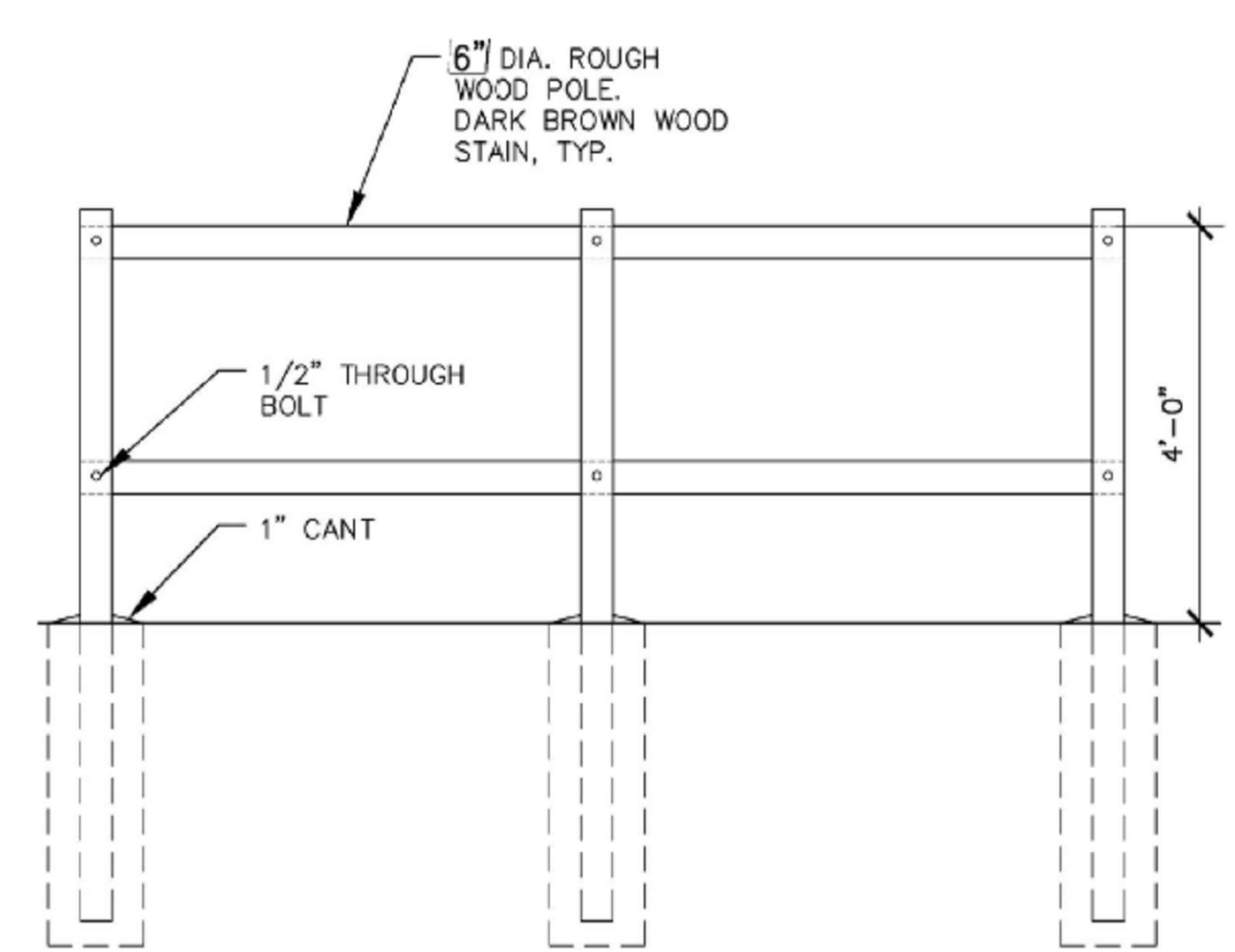
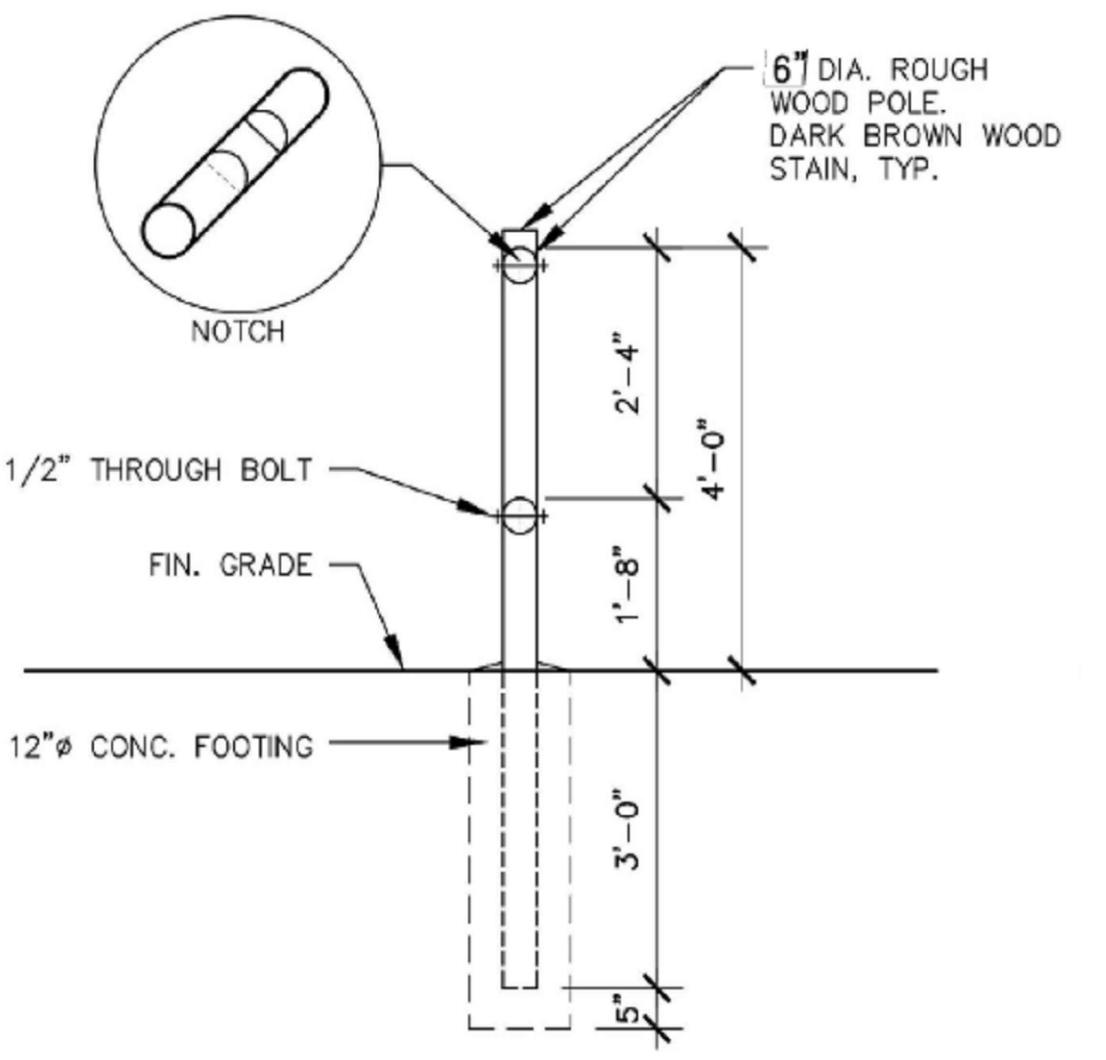

DETAIL "A"
NO SCALE

CONSTRUCTION NOTES:

- (P) PROTECT IN PLACE
- (1) CONSTRUCT 4" DECOMPOSED GRANITE MULTI-USE TRAIL PER TYPICAL SECTION ON SHEET 1
- (2) REMOVE EXISTING TREE AND ROOT SYSTEM
- (3) TRIM/PRUNE TREE TO PROVIDE MINIMUM 10' VERTICAL CLEARANCE PER CITY OF RANCHO PALOS VERDES TRAILS NETWORK PLAN.
- (4) REMOVE AND REPLACE METAL BEAM GUARDRAIL PER CALTRANS STD PLAN A77L1 (LENGTH PER PLAN).
- (5) REMOVE INTERFERING PORTIONS OF EXISTING IMPROVEMENTS TO LIMITS OF NEW MULTI-USE TRAIL IMPROVEMENTS PER TYPICAL SECTION ON SHEET 1.
- (6) ADJUST WATER METER TO GRADE (BY OTHERS).
- (7) CONSTRUCT NATURAL SURFACE TRAIL (BALANCED GRADING AND SOIL COMPACTION).
- (8) INSTALL WOOD SPLIT-RAIL FENCING PER DETAIL "A" ON SHEET 2.
- (9) REMOVE AND REPLACE CHEVRON ALIGNMENT SIGN (W1-8) ON EXISTING WOOD POST.

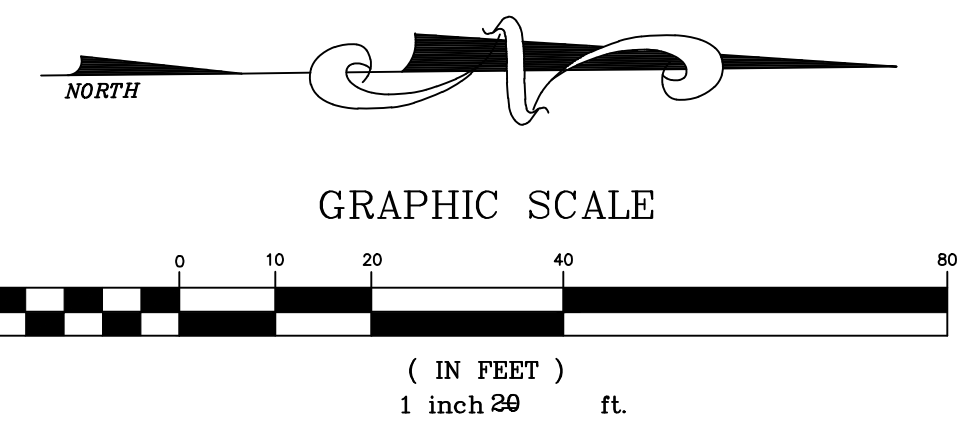

NO.	DATE	DESCRIPTION	APPROVED
REVISIONS			

DESIGNED	JW
DRAWN	JW
CHECKED	GS
DATE	04/13/18



PLANS PREPARED BY:
PENCOENG
Client Success is Our Success
 18842 VAN KARMAN AVENUE, SUITE 100
 IRVINE, CALIFORNIA 92606 (949) 753-8111
 CIVIL ENGINEERING • PLANNING • SURVEYING
 GARY ESSEX A. SOLSONA RCE 68420 DATE

75% DESIGN SUBMITTAL
 APRIL 13, 2018
 NOT FOR CONSTRUCTION
 CITY OF RANCHO PALOS VERDES

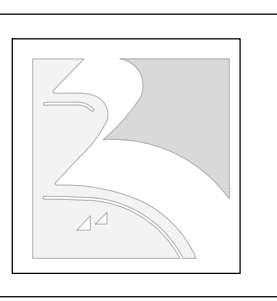

RANCHO PALOS VERDES
 CONESTOGA TRAIL CONNECTION PROJECT
 STA. 1+00 TO STA. 8+00

F:\JOB\2017\17043\TASK 01 - CONESTOGA TRAIL\CADD\SOL VISTA TRAIL\PUBLIC OUTREACH SHT 02-SHT 03.DWG (06-22-18 5:08:32PM) Plotted by: gsolsona

CONSTRUCTION NOTES:

- [P] PROTECT IN PLACE
- ① CONSTRUCT 4" DECOMPOSED GRANITE MULTI-USE TRAIL PER TYPICAL SECTION ON SHEET 1
- ② REMOVE EXISTING TREE AND ROOT SYSTEM
- ③ TRIM/PRUNE TREE TO PROVIDE MINIMUM 10' VERTICAL CLEARANCE PER CITY OF RANCHO PALOS VERDES TRAILS NETWORK PLAN.
- ④ REMOVE AND REPLACE METAL BEAM GUARDRAIL PER CALTRANS STD PLAN A77L1 (LENGTH PER PLAN).
- ⑤ REMOVE INTERFERING PORTIONS OF EXISTING IMPROVEMENTS TO LIMITS OF NEW MULTI-USE TRAIL IMPROVEMENTS PER TYPICAL SECTION ON SHEET 1.
- ⑥ ADJUST WATER METER TO GRADE (BY OTHERS).
- ⑦ CONSTRUCT NATURAL SURFACE TRAIL (BALANCED GRADING AND SOIL COMPACTION).
- ⑧ INSTALL WOOD SPLIT-RAIL FENCING PER DETAIL "A" ON SHEET 2.
- ⑨ REMOVE AND REPLACE CHEVRON ALIGNMENT SIGN (W1-8) ON EXISTING WOOD POST.

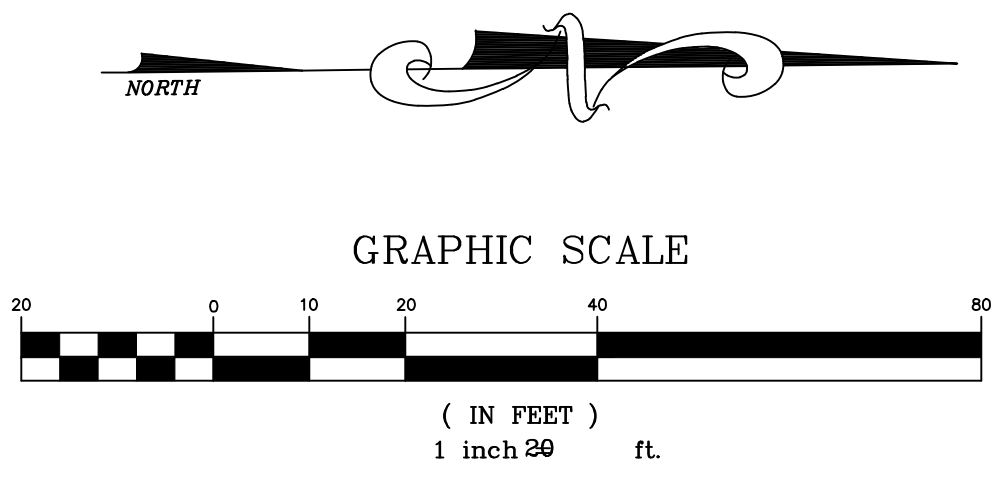
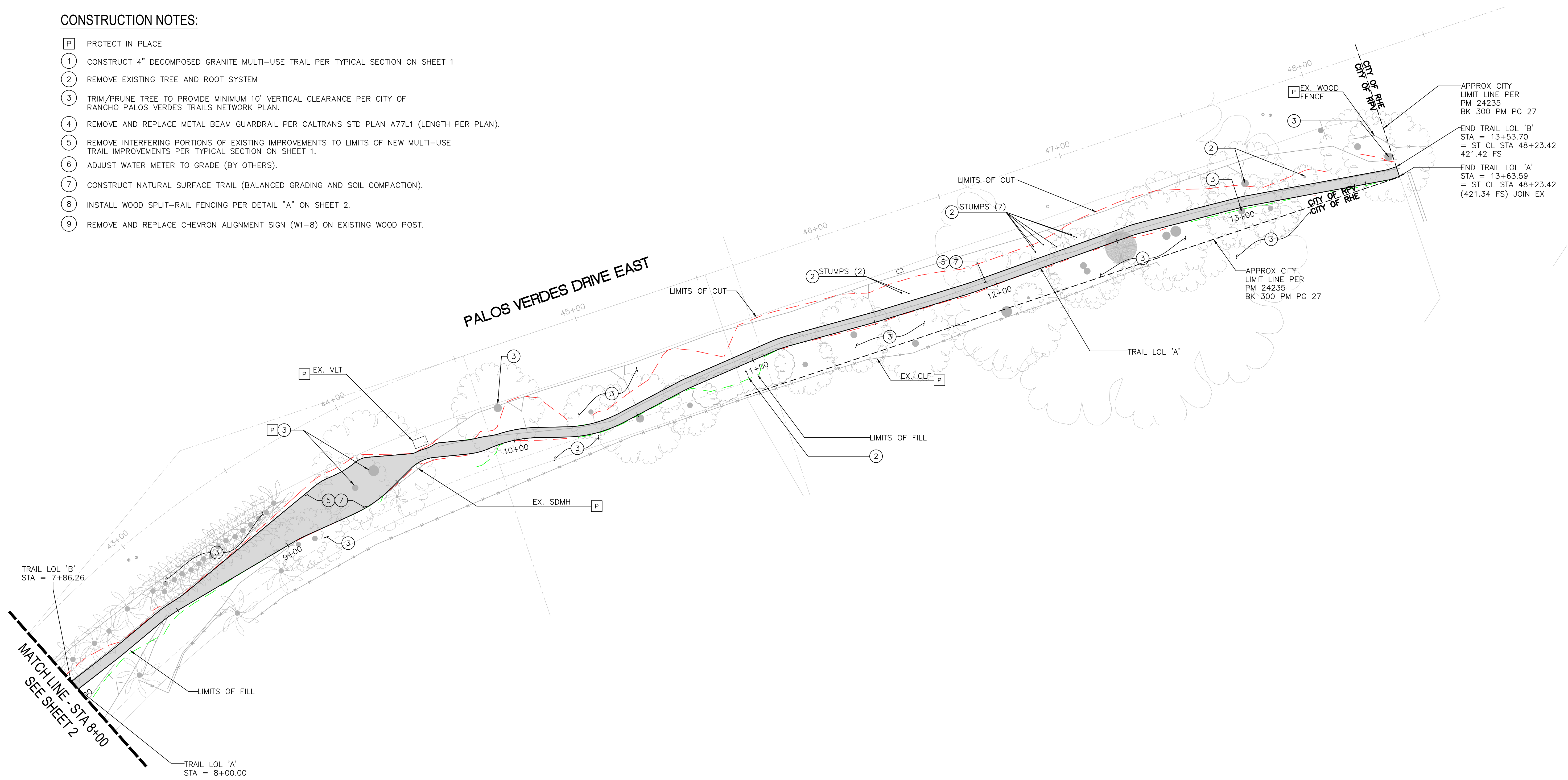

NO.	DATE	DESCRIPTION	APPROVED
REVISIONS			

DESIGNED	JW
DRAWN	JW
CHECKED	GS
DATE	04/13/18

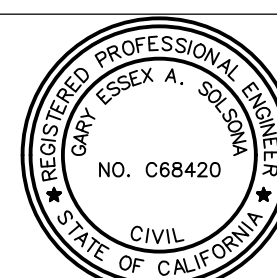

PLANS PREPARED BY:
PENCOENG
 Client Success is Our Success
 18842 VAN KARMAN AVENUE, SUITE 100
 IRVINE, CALIFORNIA 92606 (949) 703-0111
 CIVIL ENGINEERING - PLANNING - SURVEYING
 GARY ESSEX A. SOLSONA RCE 68420 DATE

75% DESIGN SUBMITTAL
 APRIL 13, 2018
 NOT FOR CONSTRUCTION
 CITY OF RANCHO PALOS VERDES



RANCHO PALOS VERDES
 CONESTOGA TRAIL CONNECTION PROJECT
 STA. 8+00 TO CITY LIMITS

F:\JOB\2017\17043\TASK 01 - CONESTOGA TRAIL\CADD\SOL VISTA TRAIL\PUBLIC OUTREACH SHT 02-SHT 03.DWG (06-22-18 5:07:11 PM) Plotted by: gsolsona