

AMENDED MAP TO ALTA VISTA GARDEN GREEN HILLS MEMORIAL PARK

Green Hills Memorial Park, a California Corporation in the County of Los Angeles, California, does hereby certify that this is a true and correct map showing the survey and subdivision into lots and plots, of the AMENDED ALTA VISTA GARDEN Section in Green Hills Memorial Park, Los Angeles County, California; that said map is located North and West of AMENDED MAP INSPIRATION SLOPE, as said Section is shown on map recorded on 09/25/03 as Doc. No. 03-2945814, BK 36, PG 85, said addition to Section is included in the "Certification and Declaration of Dedication of Cemetery Property" recorded July 20, 1948, in Book 27781, Pages 265 and 266 of the official records in the office of the County Recorder of Los Angeles County, California; that said corporation has caused to be prepared and approved that Map to which this certificate is affixed; that the Map drawn hereon correctly shows the location, arrangement, and numbering of lots and plots all situated within the boundaries of Green Hills Memorial Park in said County, as shown on recorded file Map No. 1068R, filed July 20, 1948, and recorded file Map No. 1296R filed February 6, 1953 in the office of the County Recorder of Said County; that said land was thereby dedicated and is to be used for private cemetery purposes subject to the reservation, rights and privileges set forth herein and in the dedication herein before referred and subject to all rules and regulations governing Green Hills Memorial Park now in effect and those hereafter adopted; that the said addition to section is a portion of Lot No. 1, Tract No. 3192 as per map record in Book 44, Pages 91 to 94 inclusive of maps, records of Los Angeles County, California.

The right and privilege at any time and from time to time, to resurvey, enlarge, diminish, replat, alter in shape or size, make additions thereto, and/or otherwise to change all or any part or portion of said AMENDED ALTA VISTA GARDEN Section, (including the right to establish, close, eliminate or otherwise modify or change the location of walls, walks, entrances or adjacent roads or drives, or to alter or change the arrangement or numbering of lots, plots, gardens, estates or other divisions thereof), and to file amended plats, maps, plans or elevations thereof, and to use the same for the erection of building, and/or for any purposes or uses connected with, incident to, or convenient for the care, preservation, or preparation for the disposal and/or interment of human dead bodies, and/or other cemetery purposes, together with easements and rights of way over and through said premises for, and the right and privilege of installing maintaining and operating pipelines, conduits, or drains for sprinklers, drainage, utilities, electric or communication lines, or for any other purpose is hereby expressly reserved.

GREEN HILLS MEMORIAL PARK

By: _____ Date _____
Thomas W. Frew, Chief Financial Officer

By: _____ Date _____
Nicholas R. Resich, Director of Building & Park Maintenance

A notary public or other officer completing this certificate verifies only the identity of the individual who signed the document to which this certificate is attached, and not the truthfulness, accuracy, or validity of that document.

State of California }
County of Los Angeles } ss

On _____ before me, _____

(Insert Name of Notary Public)
personally appeared **Thomas W. Frew** and **Nicholas R. Resich**, who proved to me on the basis of satisfactory evidence to be the persons whose names are subscribed to the within instrument and acknowledged to me that they executed the same in their authorized capacity, and that by their signatures on the instrument, the person or the entity upon behalf of which the persons acted, executed the instrument.

I certify under PENALTY OF PERJURY under the laws of the State of California that the foregoing paragraph is true and correct.

WITNESS my hand and official seal.

Signature _____

Name of Notary _____

County in Which Commissioned _____

Date Commission Expires _____

Commission No. _____

FND SPIKE /WASHER
RCE 26120

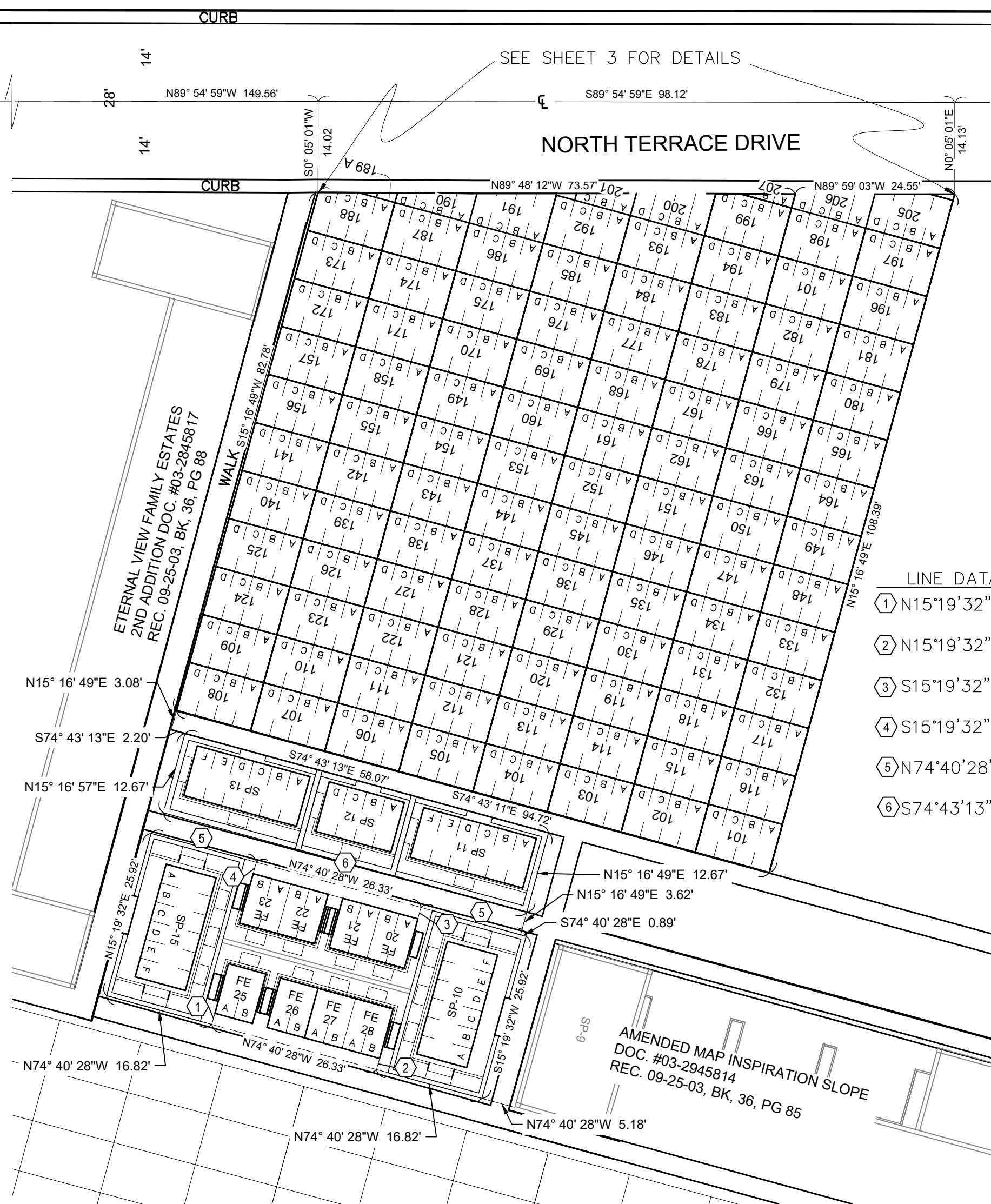

LINE DATA

- ① N15°19'32"E 1.79'
- ② N15°19'32"E 1.79'
- ③ S15°19'32"W 1.82'
- ④ S15°19'32"W 1.82'
- ⑤ N74°40'28"W 16.82'
- ⑥ S74°43'13"W 58.07'

CEMETERY MAP

GREEN HILLS MEMORIAL PARK
CITY OF RANCHO PALOS VERDES,
COUNTY OF LOS ANGELES, STATE OF CALIFORNIA

IN A PORTION OF LOT No. 1, TRACT No. 3192,
IN THE CITY OF RANCHO PALOS VERDES,
COUNTY OF LOS ANGELES, STATE OF CALIFORNIA,
AS RECORDED IN M.B. 44, PG. 91 ET. SEQ.
OF OFFICIAL RECORDS IN THE OFFICE OF THE
COUNTY RECORDER OF SAID COUNTY.

APRIL, 2020

PREPARED BY
**BOLTON ENGINEERING
CORPORATION**

25834 Narbonne Ave, Suite 210
Lomita, Ca. 90717
(310) 325-5580, Fax (310) 325-5581

This map correctly represents a survey made by me or under my direction in conformance with the Land Surveyors Act.
For Bolton Engineering Corporation

Brian G. O'Neill L.S. 8958 Exp. 9-31-20

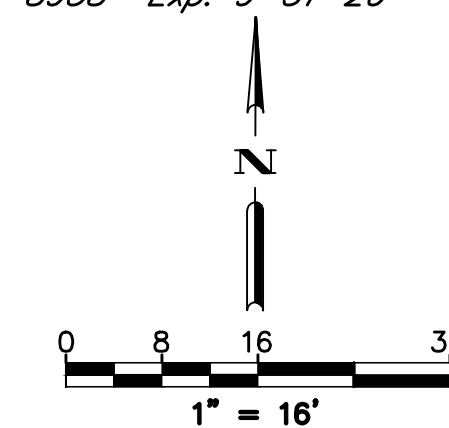

SEMI-PRIVATE (SP), AND FAMILY ESTATES (FE) AND LAWN CRYPTS LOCATION

SCALE: 1"=16' FOR DETAIL OF SP, FE, AND LAWN CRYPTS SEE SHEET 2

AMENDED MAP TO ALTA VISTA GARDEN
GREEN HILLS MEMORIAL PARK

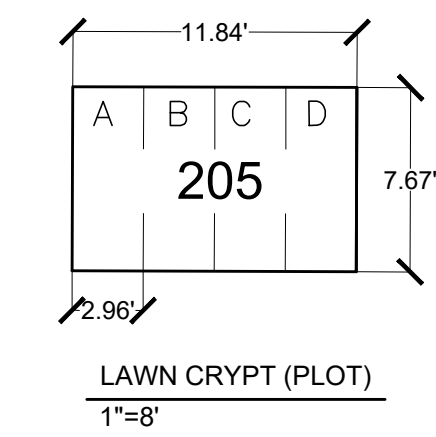
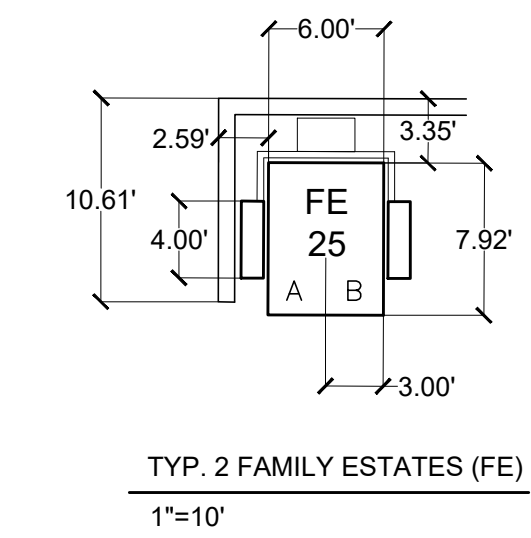
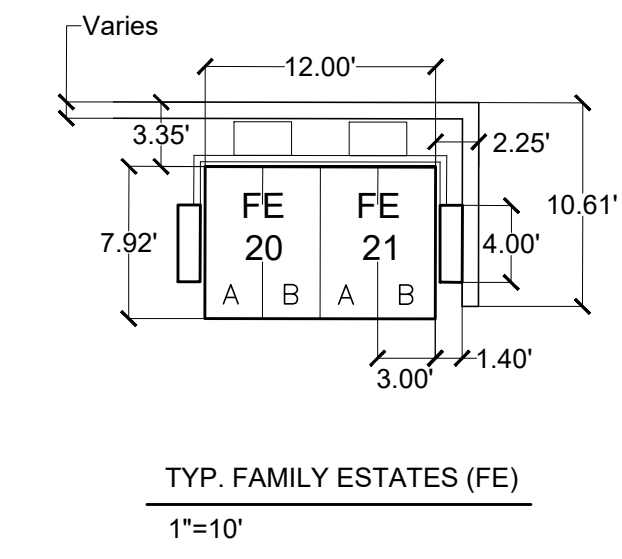
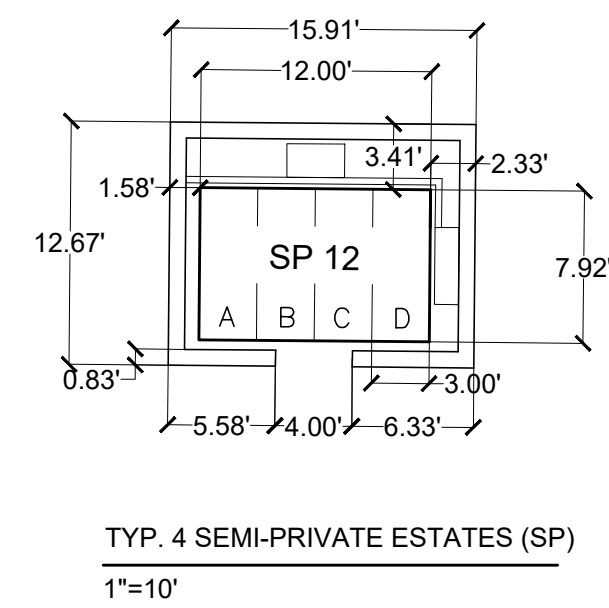
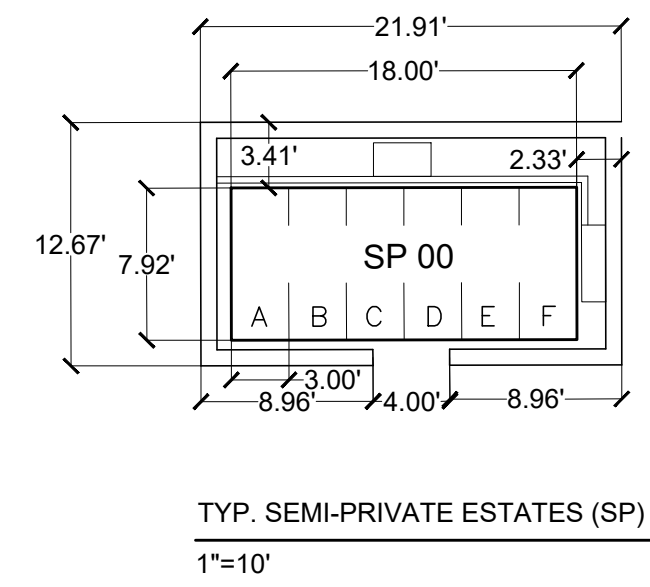
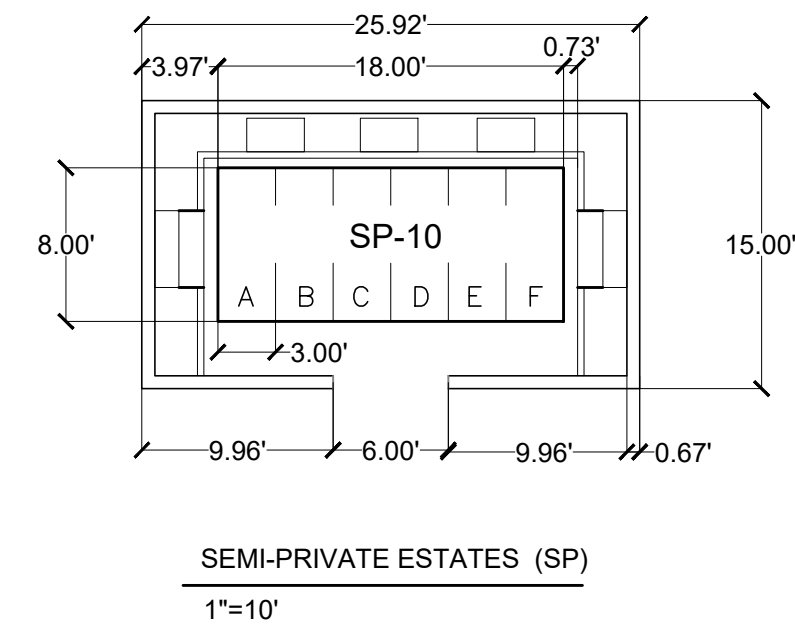

DOUBLE DEPTH CRYPTS

SP	52
FE	16
LAWN CRYPTS	381
LAWN CRYPTS (PARTIAL)	29

AMENDED MAP TO ALTA VISTA GARDEN GREEN HILLS MEMORIAL PARK

DIMENSIONS

SYMB.	LENGTHS	SYMB.	LENGTHS
A	7.95'	V	2.70'
B	3.07'	W	1.90'
C	1.01'	X	1.09'
D	2.96'	Y	7.14'
E	7.06'	Z	6.34'
F	6.25'	AA	5.53'
G	5.45'	BB	4.72'
H	4.64'	CC	3.93'
J	3.83'	DD	3.14'
K	3.02'	EE	2.35'
L	2.22'	FF	1.56'
M	1.42'	GG	0.78'
N	0.62'	HH	7.66'
P	7.50'	JJ	6.86'
Q	6.70'	KK	6.06'
R	5.90'	LL	0.68'
S	5.10'	MM	2.30'
T	4.31'	NN	2.00'
U	3.51'	PP	1.03'

