

REFER TO PAGE II, DETAIL G FOR BLDG FOUNDATIONS

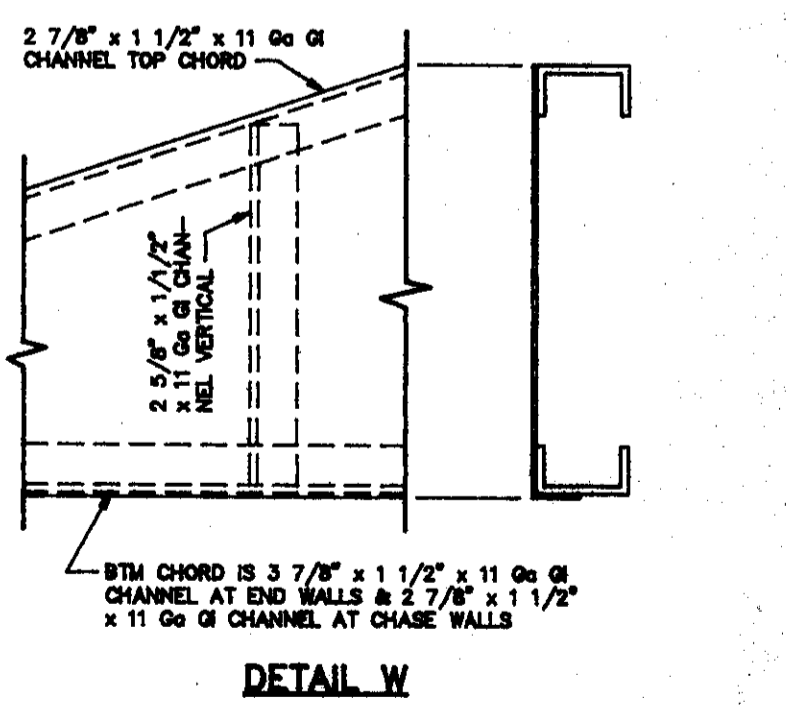
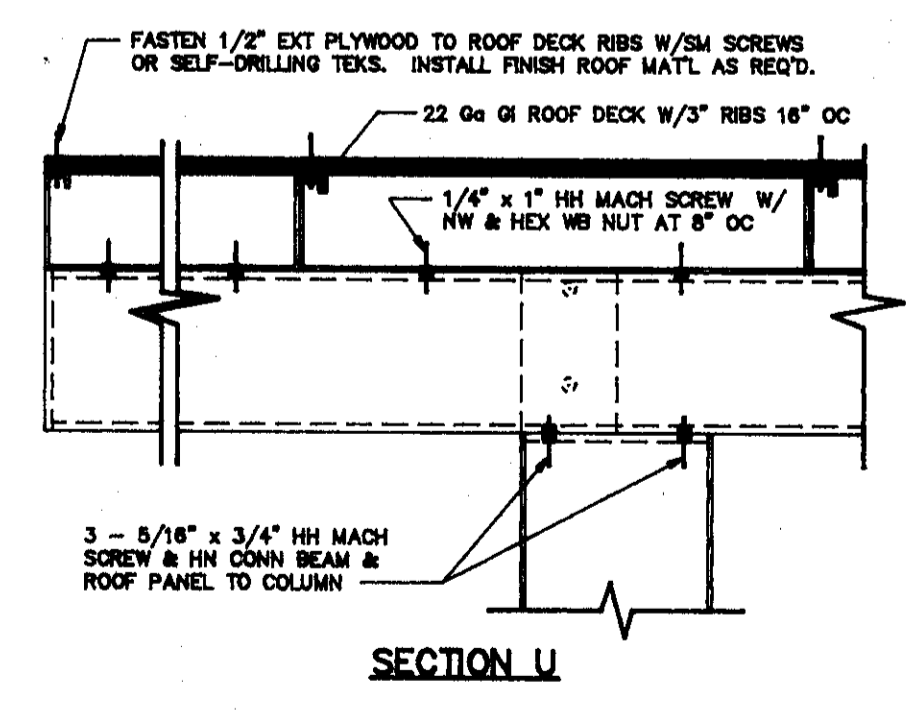
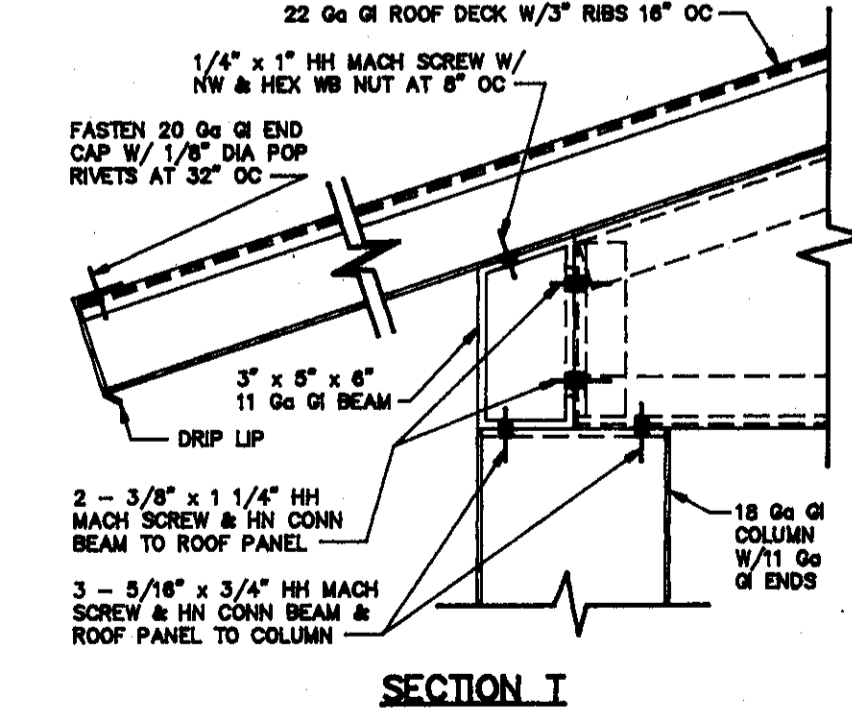
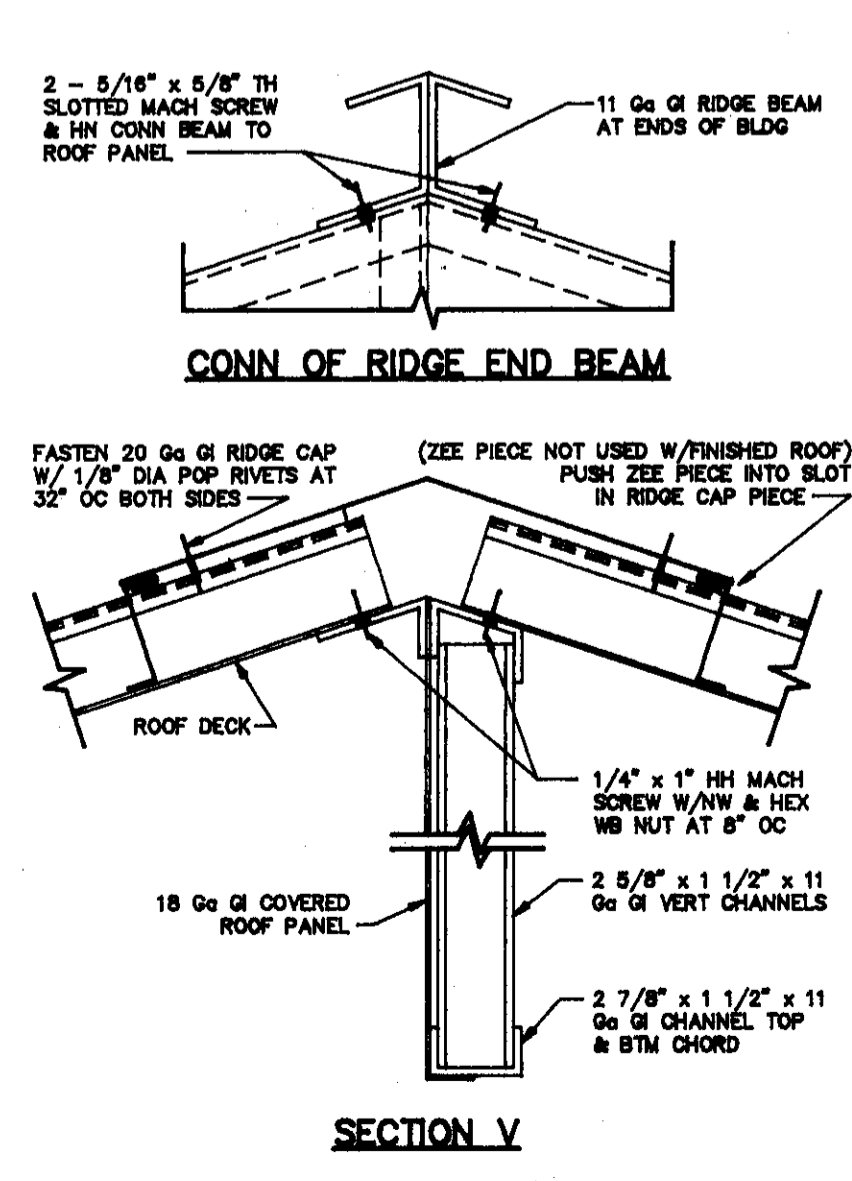
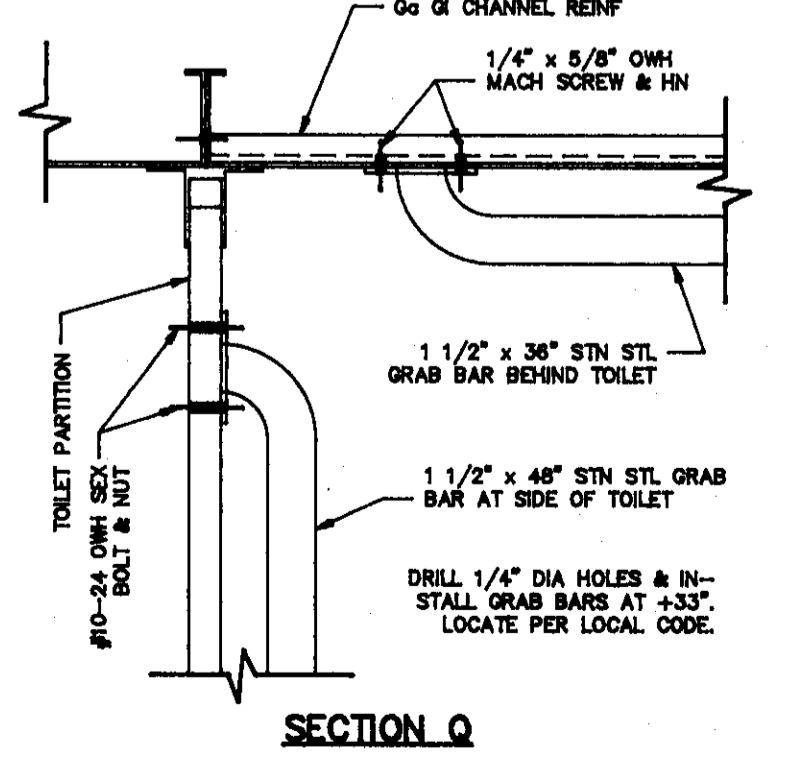
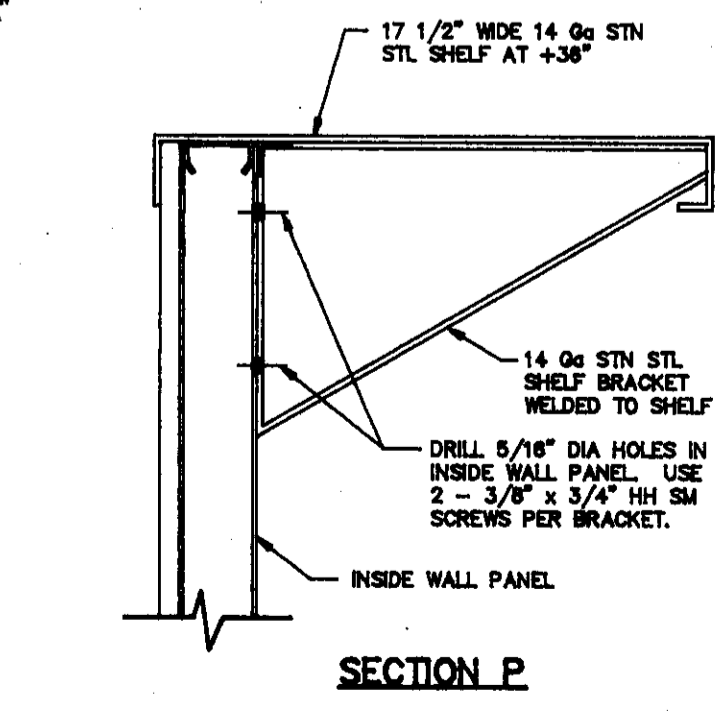
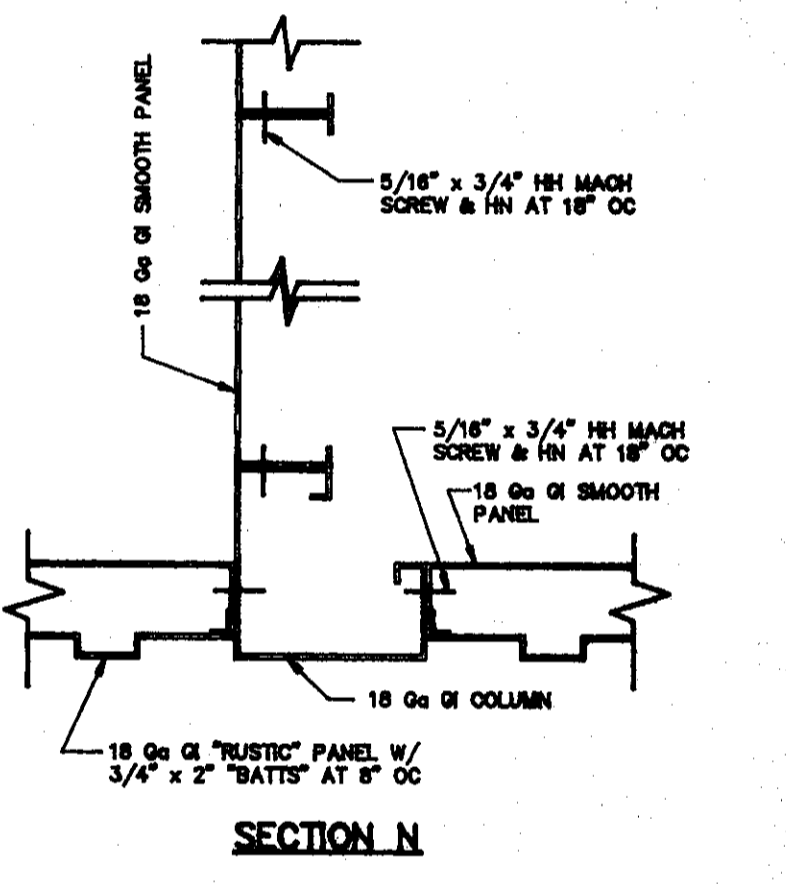
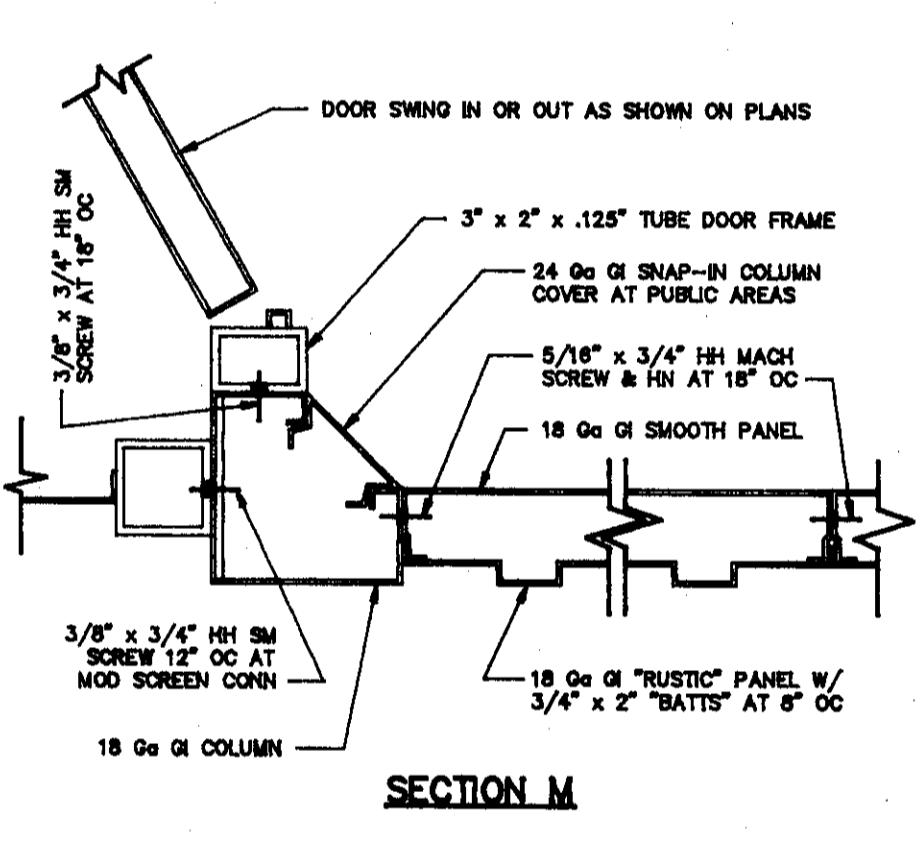
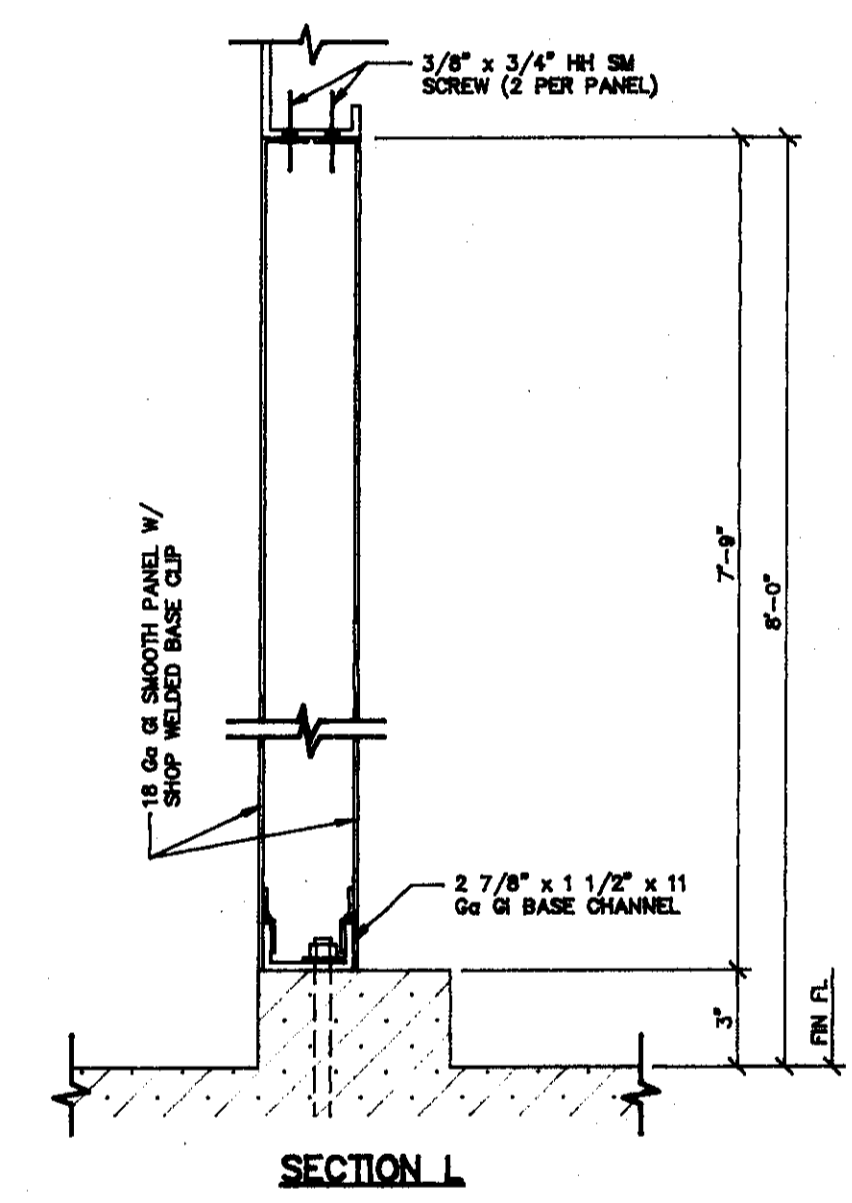
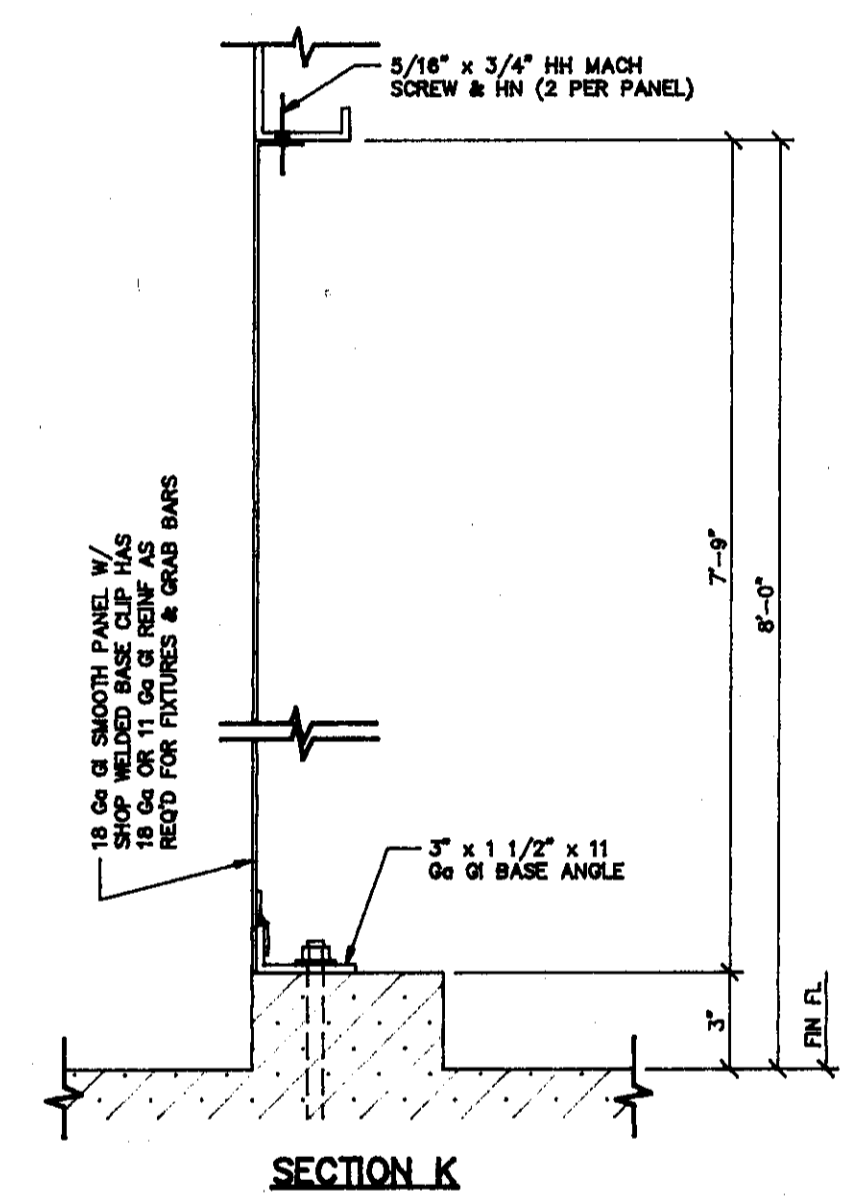
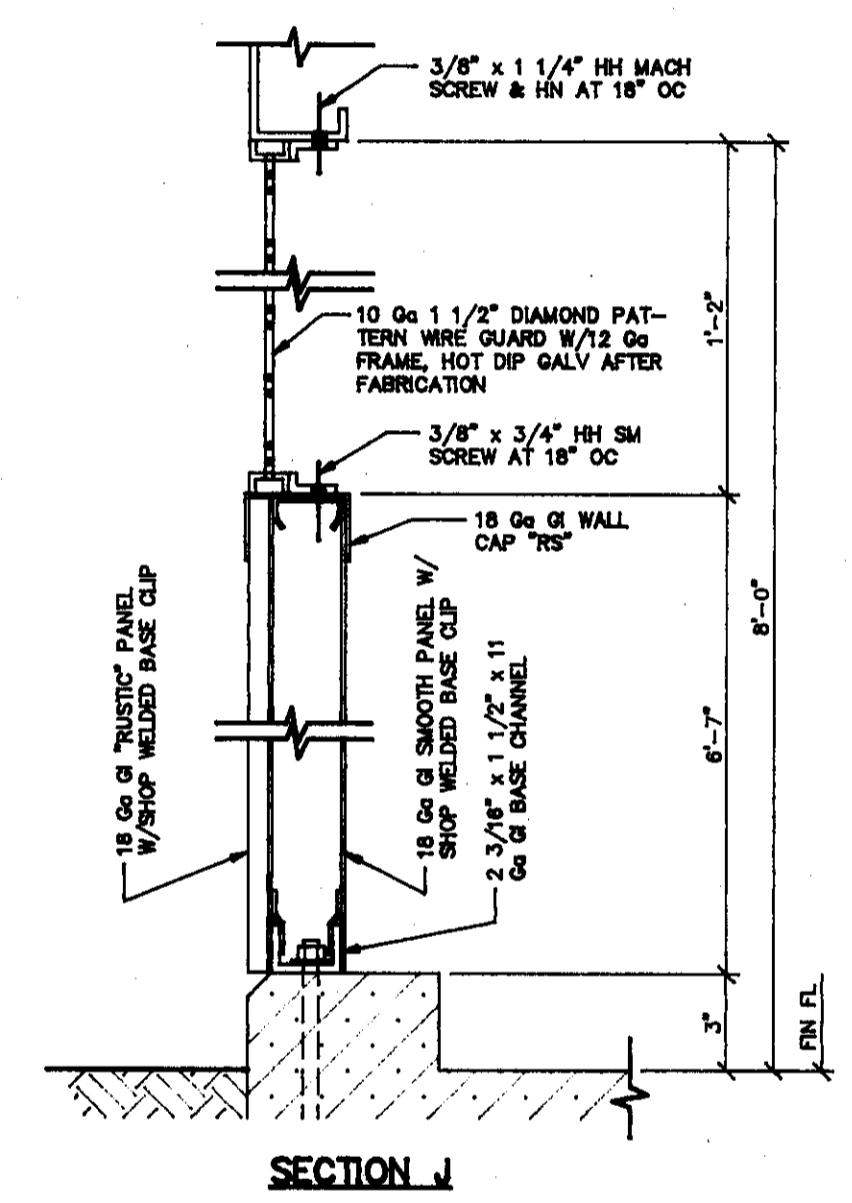
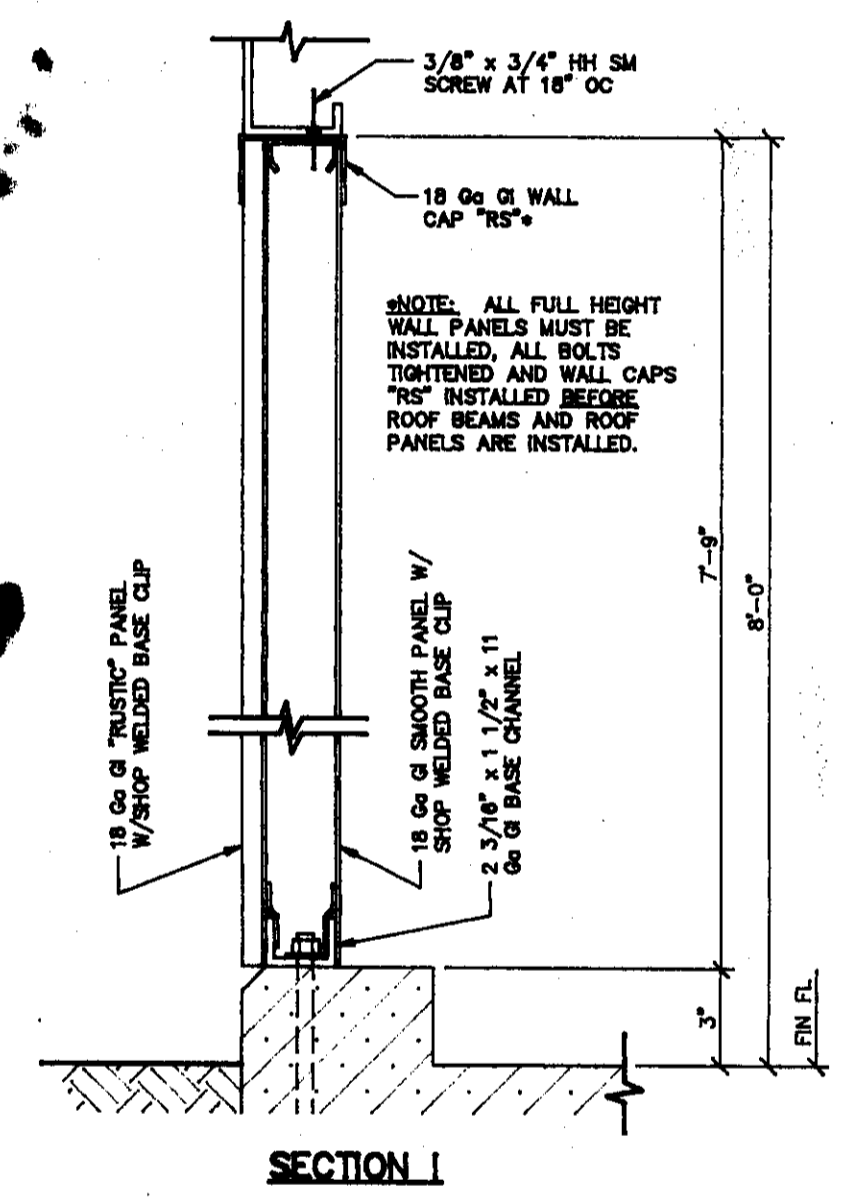

ISSUANCE OF THIS DRAWING FOR APPROVAL DOES NOT CONSTITUTE ACCEPTANCE OF CUSTOMER'S ORDER BY SUPER SECUR MFG. CO. THIS DRAWING TO BE USED IN PLACING MATERIALS SOLD UNDER THIS CONTRACT ONLY. PURCHASER TO CHECK ALL DIMENSIONS AT JOB AS SUPER SECUR MFG. CO. ASSUMES NO RESPONSIBILITY FOR FOUNDATIONS, SLAB, CONCRETE CURBS OR GENERAL BUILDING DIMENSIONS.

**MP-2325-0 22'-6" x 25'-0" SERIES 3 BUILDING W/CONCESSION / OFFICE AND STORAGE**

REV 7/19/90 LHG 10/5/90 LHG

**SUPER SECUR MFG. CO.**  
A DIVISION OF ACORN ENGINEERING COMPANY

Sales: 1195 Evans Avenue (415) 824-1778 San Francisco, CA 94124  
Factory: 15058 Proctor Avenue (818) 336-4581 City of Industry, CA 91744

DATE	DWN BY	JOB NO.	SHEET
6-28-89	LHG		A2